



## MULTIFUNCTION SOLAR SHIPPER

*Offering increased wafer and cell protection while reducing your costs*

### Overview

The new Entegris Multifunction shipper provides photovoltaic wafer, cell and module manufacturers with increased protection, high yields, improved throughput and lower costs. This shipper is ideal for transporting and sorting both square and pseudo-square wafers.

### Functions

The Multifunction shipper provides you with the following functions:

- **Shipper:** Safely ship your cells around the globe — or down the road.
- **Sort bin:** Eliminate extra process inventory by using our shipper to sort your cells within the manufacturing line. This unique function also enhances your automation capability and reduces your labor costs.
- **Storage:** Easily and securely stack for storage when wafers/cells are not in use.



### Specifications

Materials of construction:	Black proprietary polypropylene	
Dimensions:	Width:	195.58 mm (7.70")
	Length:	195.58 mm (7.70")
	Height:	73.15 mm (2.88")
Weight:	Without cells	214.5 g (7.57 oz)
	With 130 cells	1.8 kg (3.96 lb)
Maximum temperature:	60°C (140°F)	
SPI recycle code:	5 (PP)	
Patent:	Pending	

Features	Benefits
Rigid inner wall to prevent flexing	Increased wafer/cell protection
Recessed corner openings to isolate wafers/cells from shock	
Labyrinth seal keeps particles from entering shipper (see Figure 1a)	
Double walled construction dampens shock, reducing transfer of energy to cells (see Figure 1b)	
Smooth inner wall surface for minimal friction near wafer/cell edges	
Latching feature secures the top and bottom closed (see Figure 2)	Decreases your cost of ownership
Stacking feature allows shippers to nest upon one another and won't shift during storage (see Figure 3)	
Shipper can be used multiple times	
Open side walls for flat or angle mount sort bin function	Works with multiple types of sorting machines for easy installation
Locating feature for automation	Improves automation efficiencies, saving you labor costs
Optional automation clips eliminate need to manually secure shipper with tape (see Figure 4)	
Polypropylene is recyclable	Environmentally friendly option

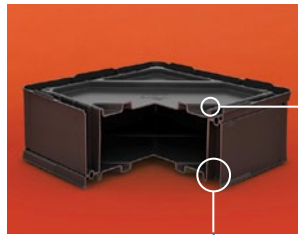

Figure 1a



Figure 2

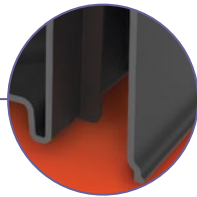

Figure 1b

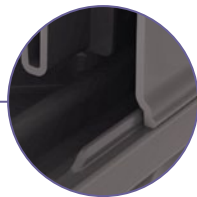

Figure 3

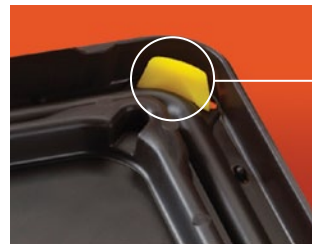

Figure 4

## Testing

### Shock Table Test Summary

Shock fragility testing was performed based on ASTM 3332-99. The shippers were loaded and secured with tape, then placed on the shock table. Using two different orientations, flat on bottom and flat on side, the shippers were introduced to a drop of 171 in/sec and 80g force.

After testing, each wafer was inspected and the Entegris Multifunction shipper performed equal to or better than standard solar shipping containers.

### Shipping Performance Test Summary

ISTA 3E simulated ship tests for packaged products were performed on the Entegris Multifunction shipper to determine its performance under the most demanding shipping conditions. These conditions included a random vibration test, an incline impact test and a rotational edge drop test. During these tests the package and product were challenged to withstand transport hazards using ISTA 3E criteria for advanced simulations. The performance of the Multifunction shipper passed all three components of these tests.

## Dimensions

Top/Bottom View

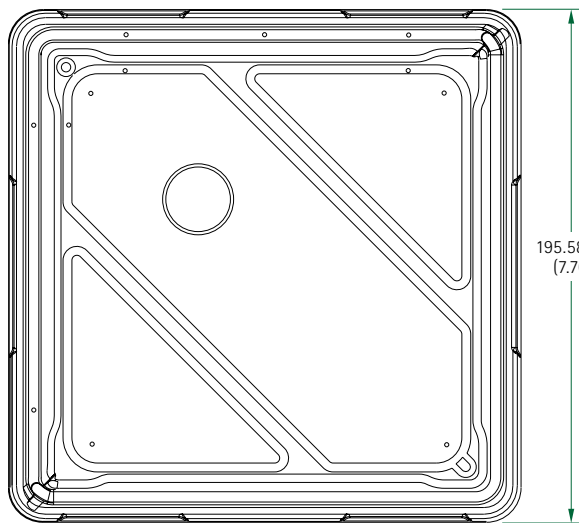

Side View

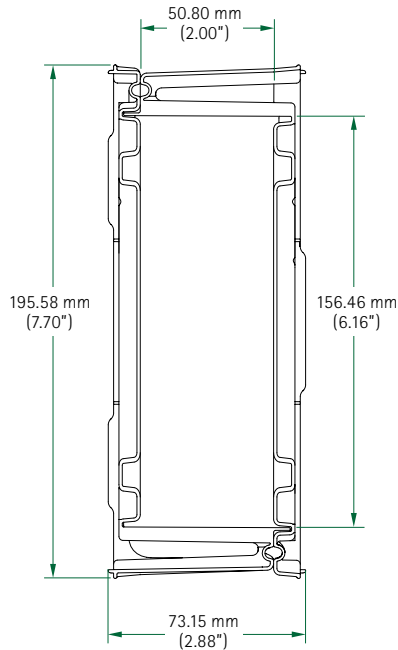

## Ordering Information

Part Number	Description
SCS156-2S101-0602	156 mm Multifunction shipper
SCS156-SC01-0603	Blue automation clip
SCS156-SC01-0607	Yellow automation clip

## For More Information

Contact us at [solar@entegris.com](mailto:solar@entegris.com) to discover how to improve yields, increase efficiencies and reduce your costs.

## Terms and Conditions of Sale

All purchases are subject to Entegris' Terms and Conditions of Sale. To view and print this information, *visit [www.entegris.com](http://www.entegris.com)* and select the Legal Notices link from the footer.

Entegris® is a registered trademark of Entegris, Inc.  
Patent pending.

---

### ENTEGRIS, INC.

Corporate Headquarters | 129 Concord Road | Billerica, MA 01821 USA  
Customer Service Tel. +1 952 556 4181 | Customer Service Fax +1 952 556 8022  
In North America 800 394 4083 | [www.entegris.com](http://www.entegris.com)