



**FLUOROPURE® HDPE DRUM WITH
SENTRY™ SINGLE LINE QUICK CONNECT**

*An innovative, high-purity chemical packaging
solution designed for the Asia/Pacific market
that is safe, cost-effective and easy to use*



*safe, cost-effective,
easy to use*

High-performance Chemical Packaging Solution

Purity and safety are maintained when transporting electronic-grade specialty chemicals in Entegris' FluoroPure® Trilayer and Advantage HDPE drums. The new Sentry™ Single Line Quick Connect System (SLQC), combined with the Entegris HDPE drum, maintains chemical integrity and provides greater adaptability to a broad range of delivery systems used in the microelectronics industry. Entegris' new package protects your valuable chemical during transportation and dispense.

Sentry™ Single Line Quick Connect Systems

The Sentry™ SLQC connection style is based on Entegris' patented Flaretek® technology. By replacing o-rings and NPT threads with a buttress thread and a Flaretek® flared sealing surface, you are assured cleaner, leak-free dispense and vent connections without chemical key coding. In addition, the Sentry™ SLQC provides a faster connection than traditional designs and is suitable for one-way or multi-use applications.

Customer Advantages

- No sealing gaskets or NPT threads in the fluid stream result in reduced particle generation and increased chemical purity
- Hand tighten feature results in faster connections because tools are not required
- Innovative design allows adaptability to numerous existing dispense system configurations
- Robust design results in superior package safety



Entegris' FluoroPure® HDPE drums meet the industry's stringent purity requirements and maintain the integrity of your valuable chemicals.

Package Assembly

Transport

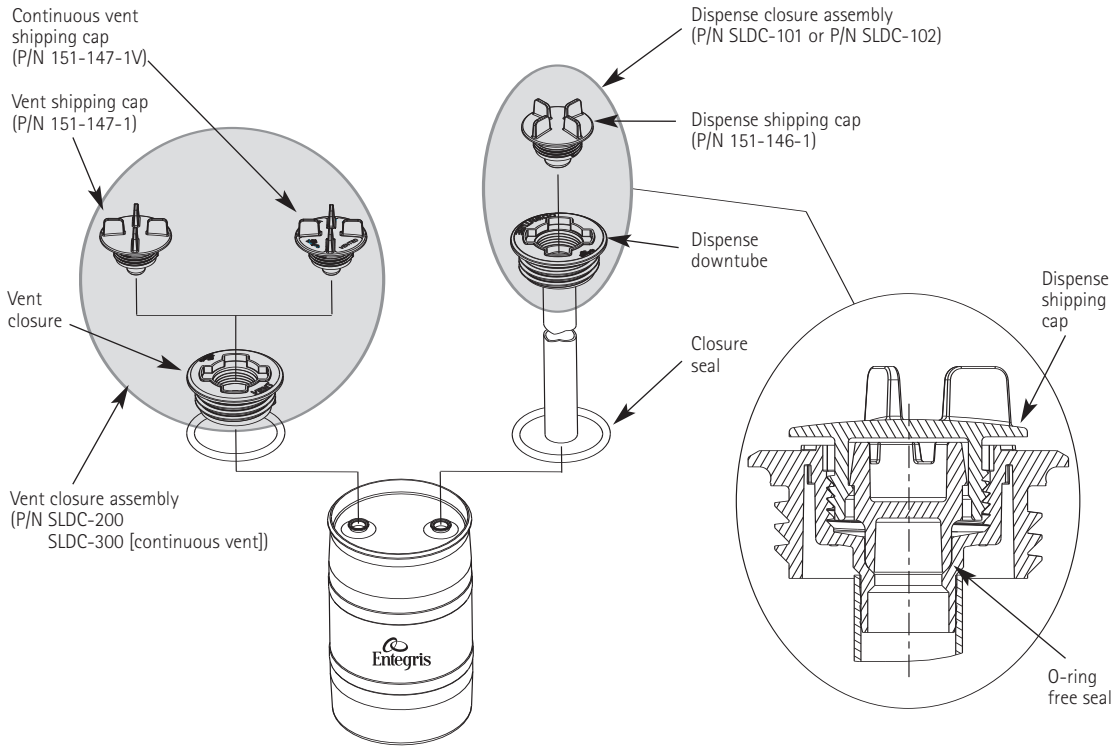

Dispense

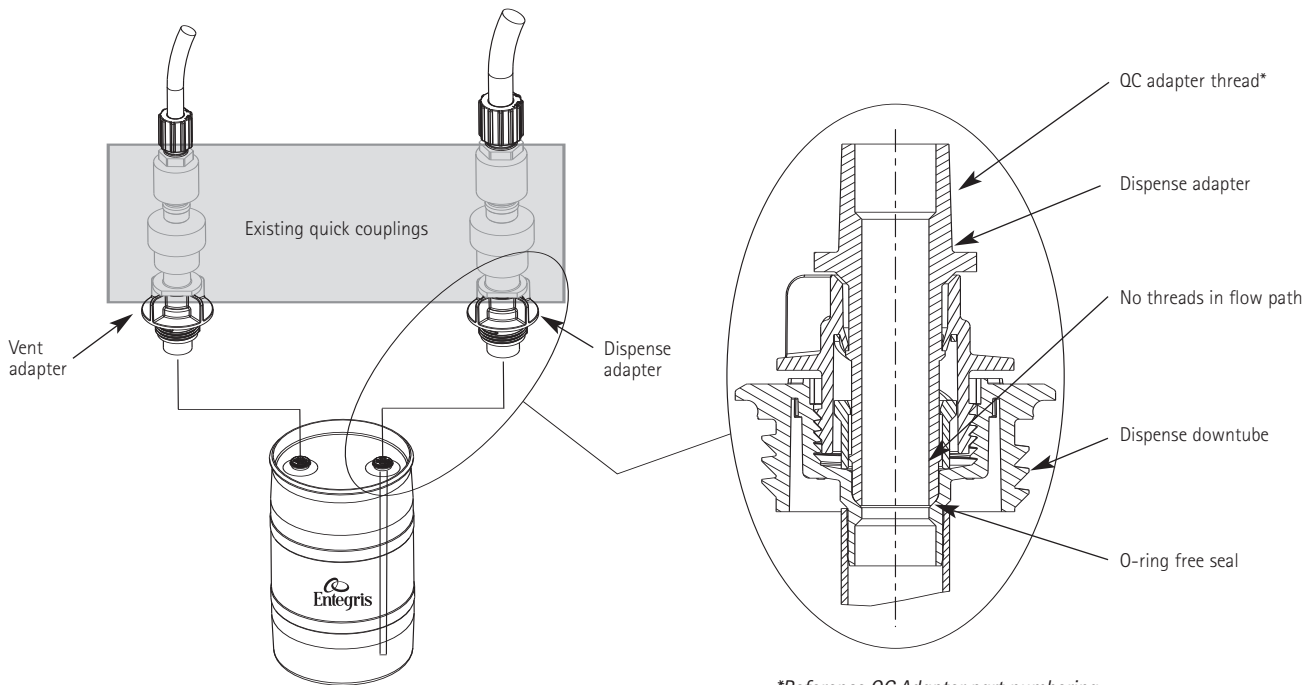

*Reference QC Adapter part numbering system for thread size options.

Dimensions

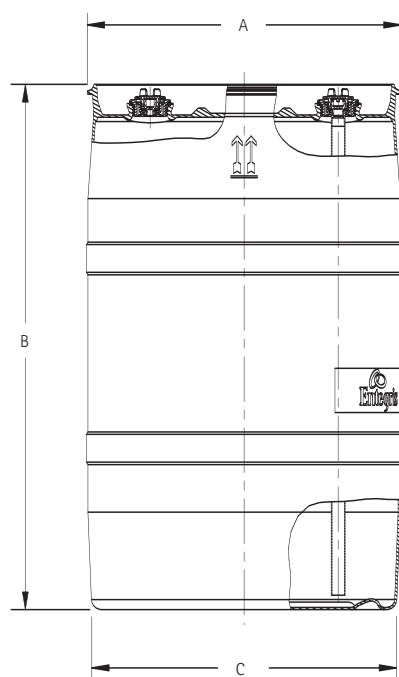

Top View

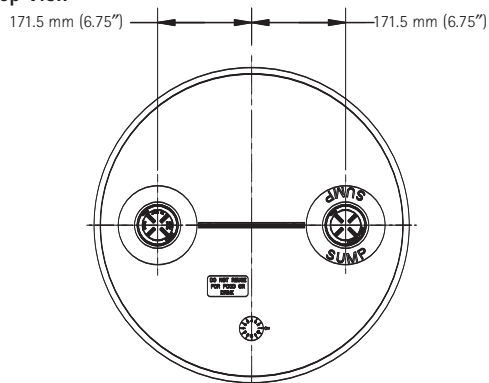

	Entegris Asia/Pacific Drum	Entegris Standard Drum
ØA	572.3 mm (22.53")	596.9 mm (23.50")
B	958.1 mm (37.72")	950.5 mm (37.42")
C	555.8 mm (21.88")	577.8 mm (22.75")

Specifications

Drum

Construction: Blowmolded multilayer high-density polyethylene

Tare weight:

Asia/Pacific Drum 11.4 kg (25 lbs.)
Standard Drum 12.5 kg (27.5 lbs.)

Size: 200 liter (55 gallon)

Approvals*:

Asia/Pacific Drum UN 1H1/Y1.9/170 TW/EPT-CR6001
UN 1H1/Y1.9/300 TW/EPT-CR6002
Standard Drum UN 1H1/Y2.0/170/2006 TW/EPT-CR6003

*FluoroPure® Trilayer and Advantage Trilayer HDPE drums manufactured in Taiwan are available in both 170 kPa and 300 kPa (ammonium hydroxide) UN ratings.

Downtube/Drum

Connection: 2" buttress thread

Transport approvals: DOT/UN Group II

Materials: Polyethylene

Options: Continuous vent shipping cap (H₂O₂)

Dispense Adapter

Drum connection: Buttress thread with Flaretek® flared seal

Fill/dispense adapter thread: 3/4" MNPT (other sizes available)**

Vent adapter thread: 1/2" MNPT (other sizes available)**

Materials: All wetted parts are PTFE, nonwetted polyethylene and ECTFE

Typical flow: K_v 214 (C_v 15)

**Reference QC Adapter part numbering system for thread size options.



In a Class 1000 cleanroom, Entegris prepares drums for shipment by performing visual and dimensional inspections, assembling drum connections and pressure-testing connections to ensure seal integrity.

Ordering Information

SLQC/HDPE Drum Package

Part Number

XX XX 00

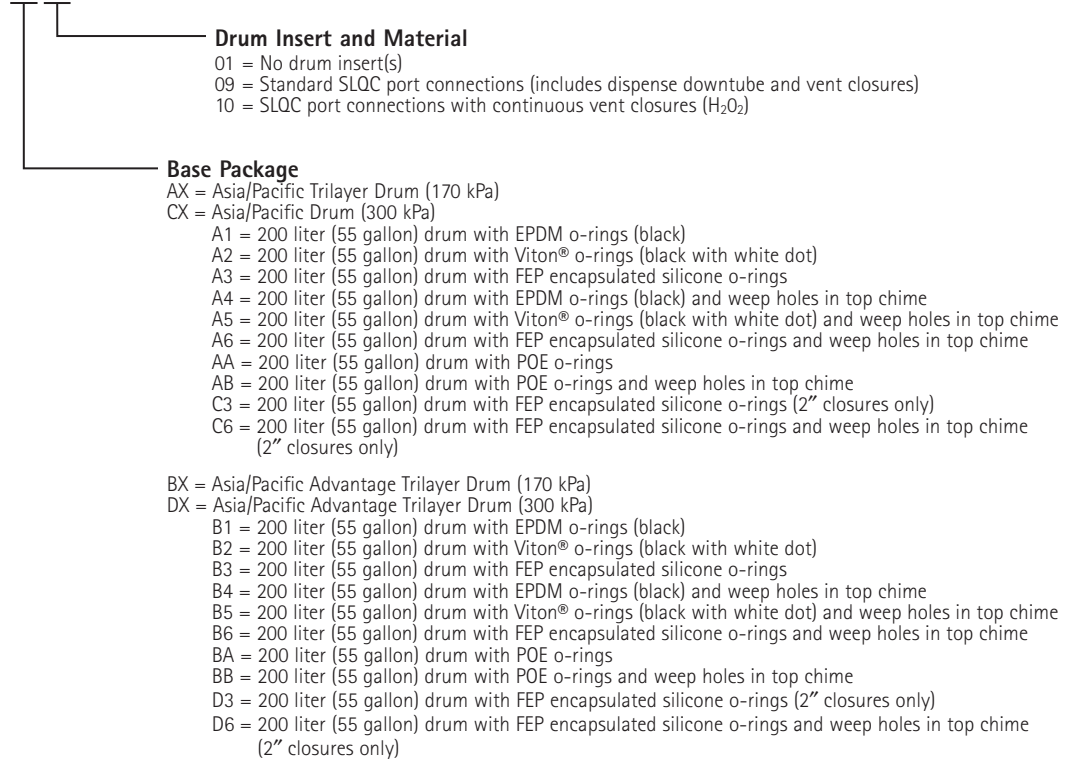

QC Adapter

Part Number

SLXX – XX X

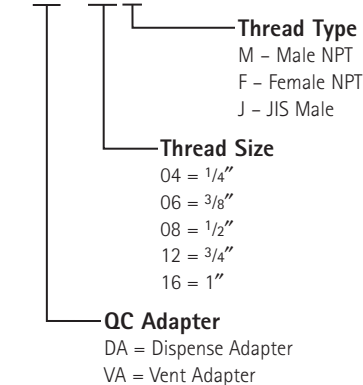

Drum Closure Assemblies

Part Number

SLDC – X XX

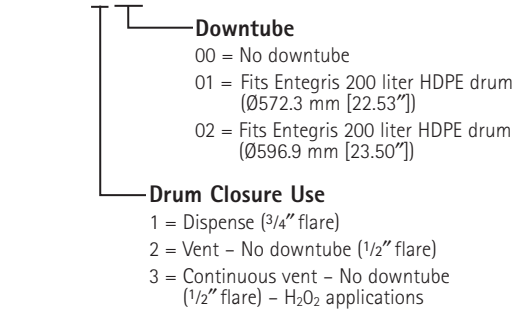

Drum Closure Components

Part Number	Description
151-146-1	Sentry™ SLQC dispense shipping cap
151-147-1	Sentry™ SLQC vent shipping cap
151-147-1V	Sentry™ SLQC continuous vent shipping cap
01-018888	Sentry™ SLQC shipping cap wrench

Terms and Conditions of Sale

All purchases are subject to Entegris' "Terms and Conditions of Sale." To view and print this information, visit Entegris' Web site at www.entegris.com and select the Legal Notices link from the footer found on the home page.

For More Information

For more information on the FluoroPure® HDPE drum with Sentry™ Single Line Quick Connect System, designed specifically for the Asia/Pacific market, or any other FluoroPure® container, contact Entegris, Inc.

To review our complete line of fluid handling products see Entegris' *Fluid Handling Products* catalog, visit Entegris' Web site at www.entegrisfluidhandling.com or contact Entegris Customer Service for your free *Fluid Handling Products* catalog on CD-ROM.

Entegris®, FluoroPure®, Flaretek®, AutoPod® and Sentry™ are trademarks of Entegris, Inc.
Viton® is a registered trademark of DuPont Dow Elastomers.

ENTEGRIS, INC.

Corporate Headquarters / 3500 Lyman Boulevard / Chaska, Minnesota 55318 USA
Customer Service Tel. 952-556-4196 In North America 800-394-4084 / Customer Service Fax 952-556-8022
www.entegris.com / www.entegrisfluidhandling.com