



**NT® INTEGRATED FLOW
CONTROLLER, MODEL 6510**

User Guide



Table of Contents

Introduction	2	Unit Operation	17
Identifying Nonstandard Product Configurations	2	Operating Environment	17
Principle of Operation	2	Performance	18
Factory Configured	3	Operational Reliability	19
Continuous versus Batch Control	3	Status and Alarming	19
Calibration Reference Conditions	3	LED Status Codes	20
General Considerations	4	Diagnostic Guide	21
Power Supply Requirements	4	Maintenance	23
Storage Temperature Range	4	Normal Operation	23
Operating Ambient Temperature Range	4	Re-zero Function	23
Operating Process Temperature Range	4	Reference	24
Line Pressure	4	Physical Specifications	24
Pressure Drop	4	Electrical Specifications	24
Dimensions	5	Performance Specifications ...	24
Installation	6	Ordering Information	25
Provided Equipment	6	Certifications	27
Mounting Requirements	7	CE Compliance	27
Mechanical Installation	8	Warranty	27
Power Supply Requirements	9	Repair and Warranty Service ...	29
Electrical Connections	11	Technical Support	29
Wiring Diagram	13		
Optional Connections	14		
Setpoint Signal Setup	15		
Calibration Graphs	16		

Introduction

This manual is for use with a standard NT® Integrated Flow Controller, Model 6510. These instruments have been designed for use in high-purity fluid applications within industries that need tightly controlled chemical processes such as the semiconductor, biomedical and solar cell industries. The wetted parts are constructed with PTFE, PFA or other similar high-purity inert materials.



WARNING!

Attempting to install or operate standard NT Integrated Flow Controllers without reviewing the instructions contained in this manual could result in personal injury or equipment damage.

Identifying Nonstandard Product Configurations

This User's Guide applies to product manufactured as the standard NT Integrated Flow Controller. Entegris also manufactures nonstandard product to meet the needs of specific applications. Nonstandard product may have different materials of construction, accuracy specifications, performance and other specifications that differentiate the nonstandard product from the standard offering.

NOTE: Nonstandard NT Integrated Flow Controllers may be identified by the model number found on the product label. Specifications

for nonstandard NT Integrated Flow Controllers are available by contacting Entegris.

Nonstandard NT Integrated Flow Controllers, Model 6510 product line, are identified with an "N" followed by a number code.

For example, in part number 6510-T2-F03-B06-A-P1-U1-N02

The "N02" designates the product as a nonstandard product manufactured to certain specifications designated under the "N02" code.

Contact Entegris for assistance with nonstandard product applications.

Principle of Operation

The user provides a setpoint signal that corresponds to the desired amount of flow. The standard NT Integrated Flow Controller compares the setpoint to the actual flow signal from the flow module. If the actual flow is greater than the setpoint, the unit closes the valve. If the actual flow is less than the setpoint, the unit opens the valve. The flow controller does this in a precise manner until the actual flow signal is equal to the setpoint.

NT Integrated Flow Controller System Diagram

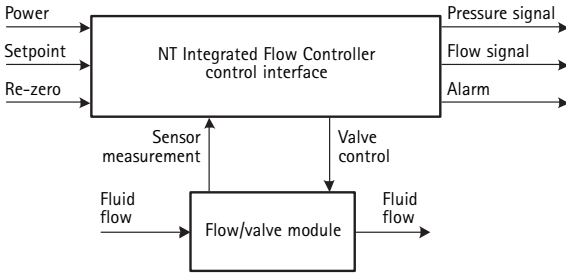

Figure 1. System diagram

Factory Configured

The standard NT Integrated Flow Controller is pre-configured from the factory for the flow range specified by the user. The specified flow range is found on the label of the unit. The unit control algorithm uses pressure and flow measurements to ensure proper operation within specification.

Continuous Versus Batch Control

The standard NT Integrated Flow Controller may be ordered as a continuous type controller or a batch type controller.

The continuous controller type is for applications requiring continuous flow rate control, where the integral valve module is never required to fully close. Typically, another valve is used in conjunction with the flow controller to stop the liquid flow.

The batch controller type is for applications requiring flow rate control where the integral valve module will fully close between batch dispense cycles. If total volume needs to be controlled, an additional separate totalizer device must be employed.

Calibration Reference Conditions

Unless otherwise noted, the specifications listed for the NT Integrated Flow Controller are referenced under the following operating conditions:

Parameter	Reference condition
Process fluid	Deionized water
Process temperature	23°C ±3°C (73°F ±5°F)
Ambient temperature	23°C ±3°C (73°F ±5°F)
Process pressure	138–207 kPa (20–30 PSIG)
Supply voltage	24 VDC ±10%
Operation	Flowmeter re-zeroed

General Considerations

The following requirements and specifications are briefly provided here. Before installing and operating the NT Integrated Flow Controller, see the *Installation and Unit Operation* sections of this user guide for more detailed information.

NOTE: The flow controller has been factory sealed. Do not attempt to remove the cover of the unit. Any attempt at removal of the unit cover will void the warranty.

Power Supply Requirements

The power supply range for the flow controller is 24 VDC \pm 10%. The power supply to the unit must provide *clean* power and must be used only to power similar measurement-type devices.

Storage Temperature Range

The flow controller can withstand storage temperatures between -40 – 65°C (-40 – 149°F) with no permanent effect on the performance of the device.

Operating Ambient Temperature Range

The flow controller is designed to operate in ambient temperature, cleanroom environments. Units indicated with P1 or P2 code sensor are specified to operate at temperatures of 10–65°C (50–149°F). Units indicated with P5 code sensor are specified to operate at temperatures of 10–35°C (50–95°F).

Operating Process Temperature Range

Units indicated with P1 or P2 code sensor interface a range of acceptable process temperatures of 10–65°C (50–149°F). Units indicated with P5 code sensor interface have a range of acceptable process temperatures of 10–35°C (50–95°F).

Line Pressure

Depending on the flow range of the flow controller being used, the system line pressure (measured at the inlet of the unit) must be 69–414 kPa (10–60 PSIG) or 83–414 kPa (12–60 PSIG).

Pressure Drop

The flow rate is calculated using Entegris' differential pressure flow technology. Depending on the flow range of the flow controller being used, the minimum pressure drop (inlet to outlet port differential pressure) required for the unit is 69 kPa (10 PSIG) or 83 kPa (12 PSIG).

Dimensions

Inlet/Outlet Port Connection	Dimensions		
	A	B	C
1/4" Flaretek®	117.8 mm (4.64")	17.0 mm (0.67")	187.5 mm (7.38")
3/8" Flaretek	117.8 mm (4.64")	17.0 mm (0.67")	191.0 mm (7.52")
1/2" Flaretek	117.8 mm (4.64")	17.0 mm (0.67")	195.1 mm (7.68")

End View

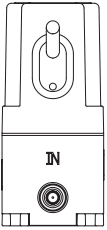

Top View

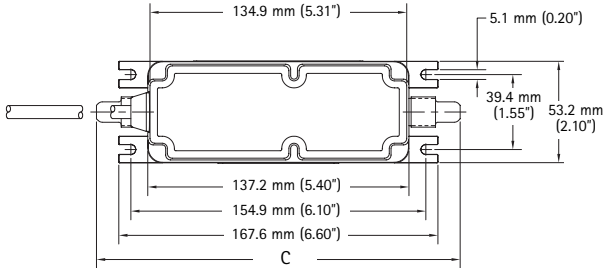

Side View

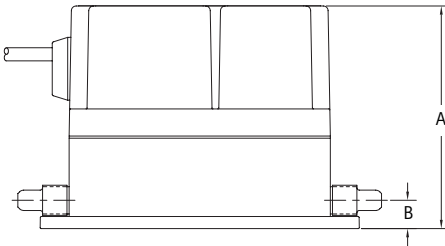

The following fitting size and flow range combinations are available:

Fitting Size	Flow Range (ml/min.)							
	TL 0-15	TT 0-25	T0 0-50	T1 0-125	T2 0-250	T3 0-500	T4 0-1250	T5 0-2500
1/4" Flaretek	Yes	Yes	Yes	Yes	Yes	Yes	Yes	—
3/8" Flaretek	Yes	Yes	Yes	Yes	Yes	Yes	Yes	Yes
1/2" Flaretek	—	—	—	—	—	Yes	Yes	Yes

Please consult the factory for custom fitting size and flow range combinations.

Installation

Provided Equipment

Verify:

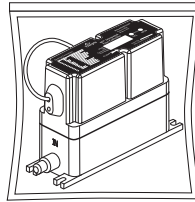
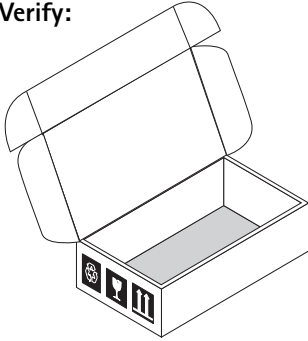

NOTE: This unit has been assembled and double-bagged under cleanroom conditions. To maintain purity, only open under cleanroom conditions.

! CAUTION:

Do not tighten the nuts that protect the flared tube connections during shipment. (See the *Prepare Fluid Lines Section on page 8*). Tightening these nuts without the proper tubing installed may damage the unit's flared tube connections.

Remove Unit from the Bag

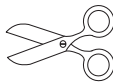
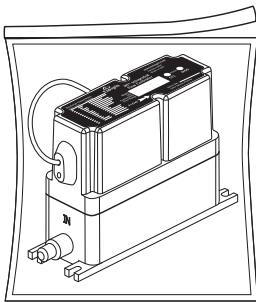

Mounting Requirements

The flow controller may be mounted in any orientation. The unit does not require straight lengths of tubing at the inlet or the outlet connection.

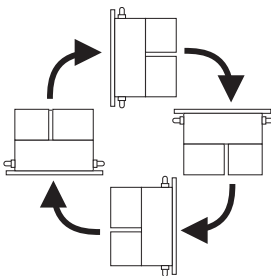

Mount the Unit

The flow controller and base bracket assembly must be mounted to a solid surface to ensure stability. Verify the valve and the electrical cable are free from mechanical stress from the surrounding equipment.

NOTE: The flow controller requires mounting in the direction of the fluid flow.

Recommended hardware

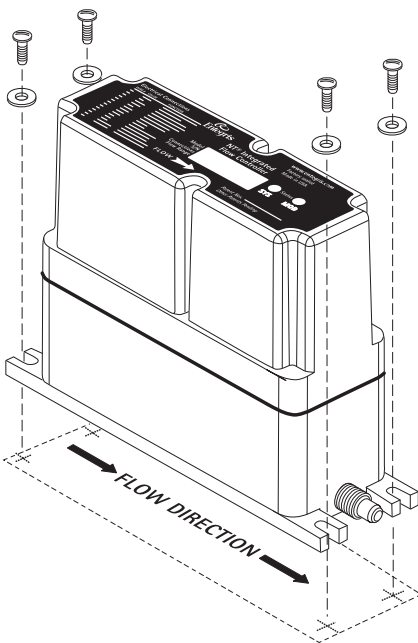
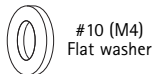

Mechanical Installation

The standard NT Integrated Flow Controller must be used with the proper tubing size and fittings.

NOTE: Flare each tube end prior to installation onto the valve fitting.

For detailed tube flaring instructions, see "Flaretek tube fitting flare and assembly procedures" at www.entegrisfluidhandling.com

! CAUTION:
• Over-tightening of the nuts will result in damage to the fitting.

Prepare Fluid Lines

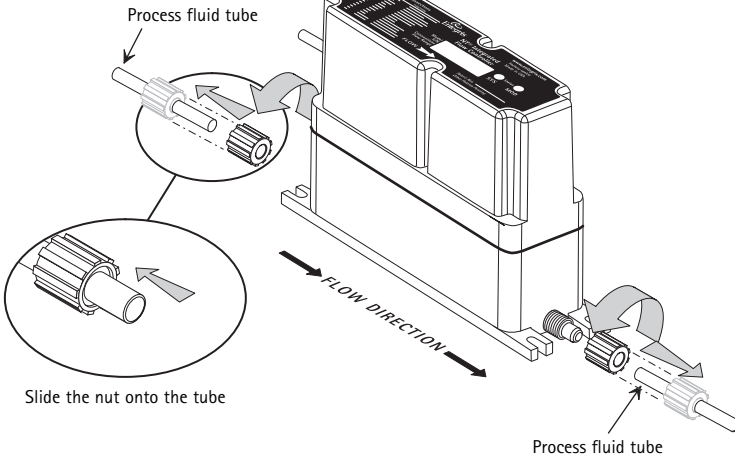

Connect Fluid Lines

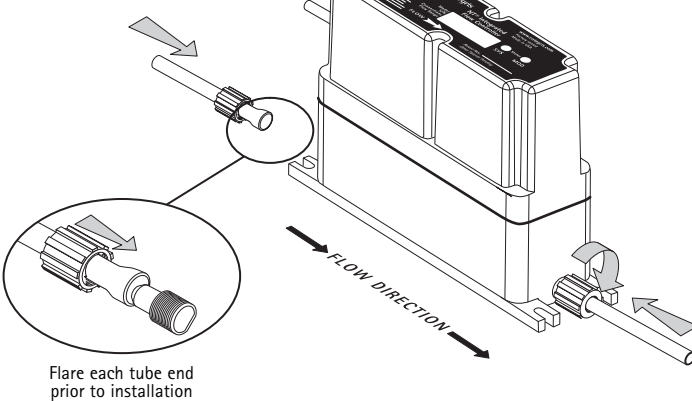

When installing flared tubing to the flow controller, the flared tube is pushed over the valve's fitting until the fitting reaches the smaller tube diameter. The amount of torque required to tighten the nut is dependent upon the size of the fitting.

Fitting Size	1/4"	3/8"	1/2"
Torque (in•lbs.)	5	8	11
Torque (N•m)	0.56	0.90	1.24

Care should be taken when installing the flow controller to avoid fluid leaks. Do not use excessive torque or subject the unit to high heat during installation. The unit and base bracket assembly must be mounted to a solid surface to ensure stability. Verify the body and the electrical cable are free from mechanical stress from the surrounding equipment.

Power Supply Requirements

The power supply range for the flow controller is 24 VDC ±10% regulated. The power supply must provide continuous 1.0 ampere (nominal) service for each flow controller installed. The power supply requirements must be met at the wire connections or connector of the flow controller, not only at the power supply itself.

The power supply to the unit must provide clean power and must be used only to power similar measurement-type devices. The power supply must not be used to power other inductive loads, such as motors, relays, or solenoids. These devices may produce electrical transients that may affect unit measurements.

An induced power spike, creating an interruption in power greater than 10 milliseconds in duration, may cause the unit to reset.

In addition to providing clean power, the instrumentation signals and power return lines must not be run within the same conduit or cable along with heavy current demands from motors, charging capacitors or other inductive loads. This may cause a voltage change within the instrumentation signal line, causing erroneous output readings from the flow controller. Loss of power will not cause the loss of any system parameters or calibration values.

Input Impedance of the Voltage Setpoint

The input impedance of the voltage setpoint is 37 kOhm.

Voltage Drop at the 4–20 mA Setpoint Input

The 4–20 mA input will drop 4.6 V at 20 mA. Input impedance is 230 ohms.

Lift-off Voltage of the 4–20 mA Output Loops

The minimum lift-off voltage of the 4–20 mA output loops (flow, pressure measurements) is 12 VDC. The minimum lift-off voltage is the voltage required at the unit for proper operation. The maximum load resistance for a 24 VDC supply is 600 ohms and includes the resistance of measurement devices and the interconnecting cable.

Output Load Resistance Effects

Using a 24 VDC power supply, the two 4–20 mA output loops (flow and pressure) will experience no shift if the load resistance is 0–600 ohms.

Reverse Polarity Protection

The flow controller is reverse polarity protected; connecting the 24 VDC power to any wires will not harm the unit. To operate properly, the polarity must be correct.

Over-voltage on any Wire (DC)

In the event of accidental application of voltage greater than 24 VDC $\pm 10\%$, the flow controller will withstand continuous 30 VDC on any wire without compromising the unit.

Over-voltage on any Wire (AC)

The flow controller is not designed to withstand the accidental application of 110/220 VAC to any wire. Application of AC voltage will damage the unit.

Short Protection

The flow controller will not be damaged or compromised in any way if any combination of wires are shorted together.

Circuit Protection

Fuse the three input power lines to each individual NT Integrated Flow Controller, Model 6510. The three lines are:

- 2-Red/Pin R, +24 VDC (main power, 1.0 Amp nominal)
- 3-Orange/Pin M, Flow output, +24 VDC supply
- 4-Yellow/Pin T, Pressure output, +24 VDC supply

Use a 2 Amp rated, time lag fuse. A single fuse can be used for all three input power lines combined, or individually, as preferred. Place the fusing on the input power lines to the unit at the equipment electrical enclosure to ensure that both the wiring to the unit and the unit itself are protected from any over-current condition. Best practice is to locate the fuse away from the typical liquid exposure or harmful vapor areas. Locating it within the electrical enclosure shared by the power supply enables accessibility for troubleshooting or replacement.

Electrical Connections

Pigtail Electrical Cable

Units specified with a pigtail electrical connection are manufactured with a permanently attached cable.

Table 1 details the wire connections for the flow controller type with pigtail electrical cable.

WIRE CONNECTIONS – PIGTAIL CABLE

Wire Color	Marker No.	Function
Yellow	4	Pressure output, +24 VDC supply
Brown	1	Pressure output, 4–20 mA output
Orange	3	Flow output, +24 VDC supply
Blue	5	Flow output, 4–20 mA output
Green	9	Re-zero input
Pink	11	Setpoint, voltage, 0–10 or 0–5 VDC
Gray	12	Setpoint, common
Tan	10	Setpoint, current, 4–20 mA
Black	8	Ground (+24 VDC common)
Red	2	+24 VDC
Violet	6	Factory use only – do not connect
White	7	Factory use only – do not connect
White/Red Dot-Dash	13	Alarm (non-polarized)
White/Red Dot-Dash	14	Alarm (non-polarized)

Table 1. Wire connections – pigtail cable

Pigtail Cable

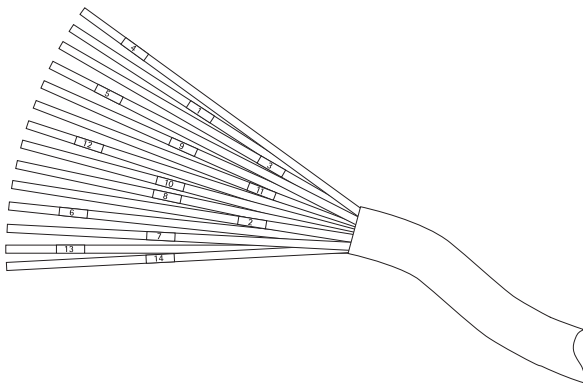

G-Series Electrical Connector

Units specified with a G-Series connector use a Turck brand, versafast® style, BSMK type, constructed of polyurethane with a nylon coupling nut. The connector is over-molded onto an electrically shielded, PVC-jacketed cable. The pin contacts for the electrical connection are gold-plated for performance and corrosion resistance. The connector is physically “keyed,” making it easy to connect to a receptacle. Press it into a receptacle and turn the threaded coupling nut to draw the connector and receptacle together until finger tight. G-series connectors to pigtail mating cables are available. See the *Ordering Information Section* of this user guide.

The following pin diagram and Table 2 detail the wire connections for the flow controller type with G-series electrical connector.

WIRE CONNECTIONS – G-SERIES CONNECTOR

Pin	Function
R	+24 VDC
E	Ground (+24 VDC common)
T	Pressure output, +24 VDC supply
A	Pressure output, 4–20 mA output
M	Flow output, +24 VDC supply
L	Flow output, 4–20 mA output
J	Re-zero input
U	Setpoint, current, 4–20 mA
G	Setpoint, voltage, 0–10 or 0–5 VDC
S	Setpoint, common
O	Factory use only – do not connect
P	Factory use only – do not connect
C	Alarm (non-polarized)
N	Alarm (non-polarized)

Table 2. Wire connections – G-series connector

Mandatory Connections

2-Red/Pin R and 8-Black/Pin E wires must be connected according to Table 1, Table 2 and the *Wiring Diagram* on page 13. The setpoint must also be connected to 10-Tan/Pin U wire (4–20 mA setpoint) and 12-Gray/Pin S wire (common setpoint) or to 11-Pink/Pin G wire (voltage setpoint) and 12-Gray/Pin S wire (common setpoint). Connect 9-Green/Pin J (re-zero input) to switched, normally open 24 VDC $\pm 10\%$ main power supply in order to have the same ground as the 8-Black/Pine E (ground).

NOTE: the 24 VDC connected to re-zero must be the main power supply in order to have the same ground as 8-Black/Pin E. See the *Maintenance Section* of this user guide for re-zero instructions.

Consult factory with any questions about electrical installation.

Unused Connections

The 6-Violet/Pin O and 7-White/Pin P wires are for factory use only. Do not connect to power supply or ground. These wires must remain disconnected.

Plug Orientation, Face View

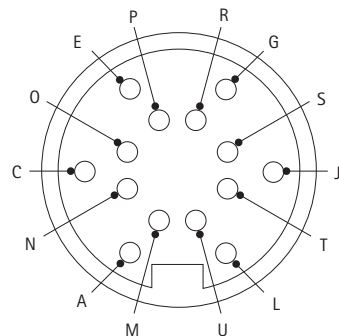

Wiring Diagram

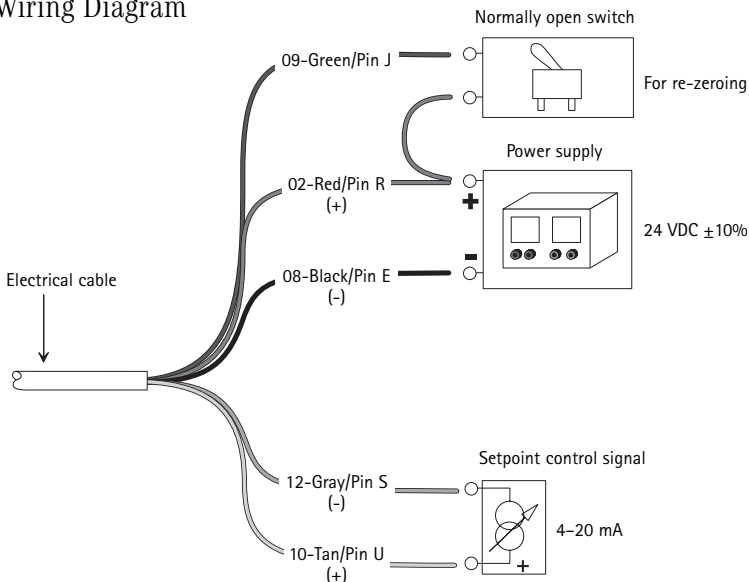

OR

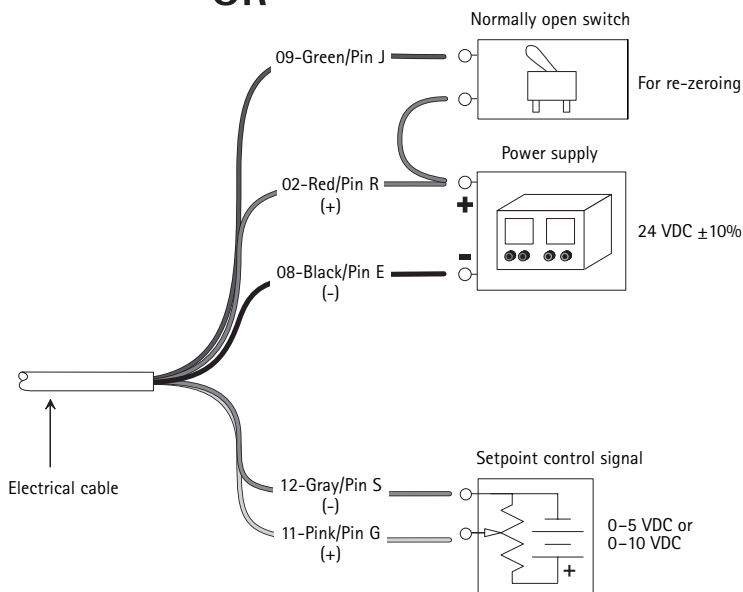

Optional Connections

To monitor flow rate, apply 24 VDC to 3-Orange/Pin M wire and measure the 4–20 mA flow output signal from 5-Blue/Pin L wire.

To monitor inlet pressure, apply 24 VDC to 4-Yellow/Pin T wire and measure the 4–20 mA pressure output signal from 1-Brown/Pin A wire.

These outputs are electronically isolated from all other circuit connections. Using a separate power supply is possible.

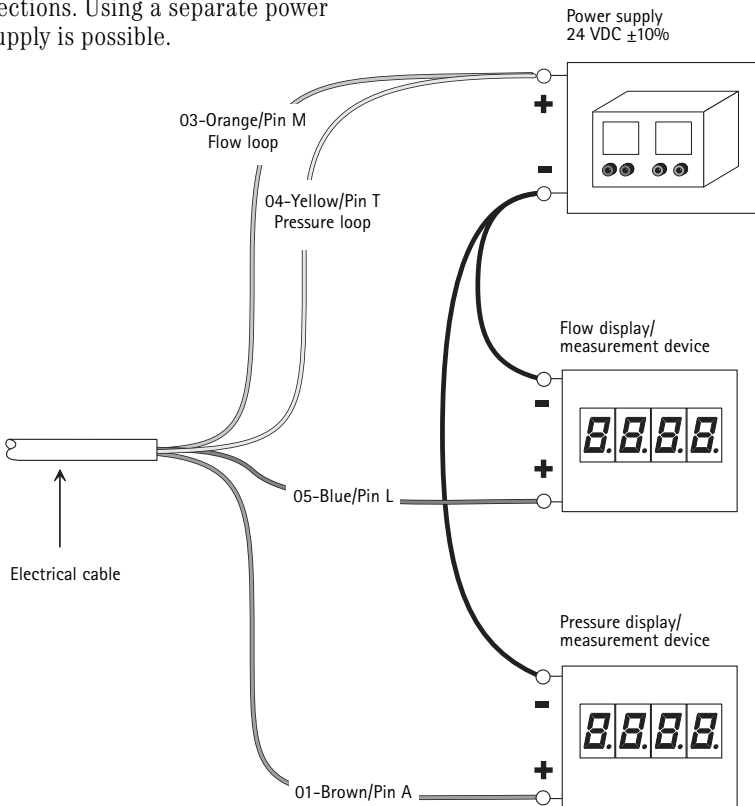

Setpoint Signal Setup

Use the following formulas to adjust your setpoint signal output device to match the flow range of the unit. Repeat the calculations for multiple control points.

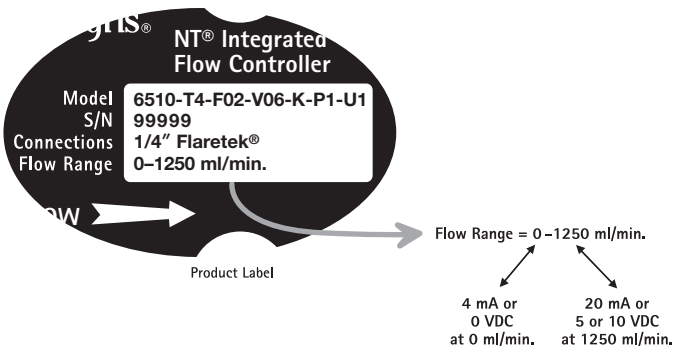

Formulas and Example Calculations

F = Desired Flow (ml/min./l/min.)
 FS = Full Scale Flow (ml/min./l/min.)

Span = Range of the Output Signal

4-20 mA Setpoint Control Signal

$$\text{Setpoint}_{\text{mA}} = \frac{F \times \text{Span}}{\text{FS}} + 4 \text{ mA}$$

Range of Product = 0-1250 ml/min.
F = 125 ml/min.
Span = 20 mA - 4 mA = 16 mA
FS = 1250 ml/min.
 Setpoint_{mA} = $\frac{(125 \text{ ml/min.}) \times (16 \text{ mA})}{(1250 \text{ ml/min.})} + 4 \text{ mA}$
 Setpoint_{mA} = 5.6 mA

0-5 VDC or 0-10 VDC Setpoint Control Signal

$$\text{Setpoint}_{\text{VDC}} = \frac{F \times \text{Span}}{\text{FS}}$$

Range of Product = 0-1250 ml/min.
F = 500 ml/min.
Span = 10 VDC - 0 VDC = 10 VDC
FS = 1250 ml/min.
 Setpoint_{VDC} = $\frac{(500 \text{ ml/min.}) \times (10 \text{ VDC})}{(1250 \text{ ml/min.})}$
 Setpoint_{VDC} = 4.0 VDC

Calibration Graphs

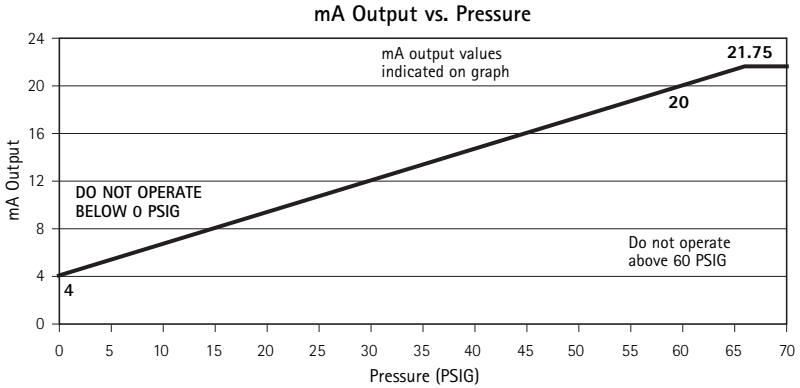
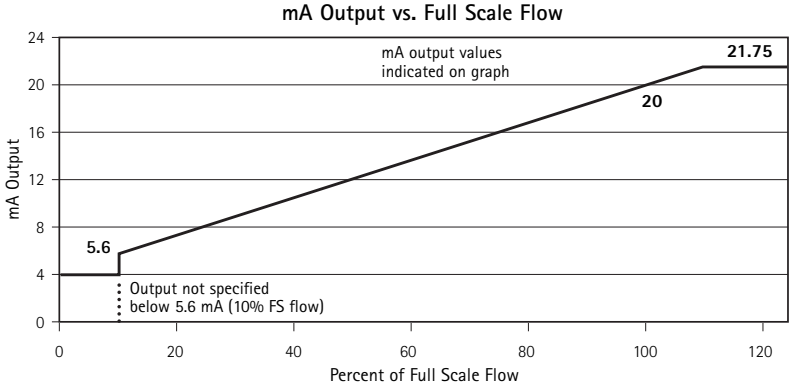

NOTE: Specifications are subject to change without notice. Please consult the factory for the most current information.

Unit Operation

Operating Environment

Storage Temperature Range

The flow controller can withstand storage temperatures between -40 – 65°C (-40 – 149°F) with no permanent effect on the performance of the device.

Operating Ambient Temperature Range

The flow controller is designed to operate in ambient temperature, cleanroom environments. Units indicated with P1 or P2 code sensor are specified to operate at temperatures of 10 – 65°C (50 – 149°F). Units indicated with P5 code sensor are specified to operate at temperatures of 10 – 35°C (50 – 95°F). For operation above 65°C (149°F), contact the factory. The unit must be re-zeroed at operating ambient temperature conditions and after any temperature change for the accuracy specifications to apply. See the *Maintenance Section* on page 23 for re-zeroing instructions.

Operating Process Temperature Range

Units indicated with P1 or P2 code sensor interface have a range of acceptable process temperatures of 10 – 65°C (50 – 149°F). Units indicated with P5 code sensor interface have a range of acceptable process temperatures of 10 – 35°C (50 – 95°F). When the process fluid is above ambient temperatures of 23°C (73°F), the system will experience slight accuracy errors due to instrument warm-up and changes in viscosity and specific gravity of the

liquid. The unit must be re-zeroed at operating process temperature conditions and after any temperature change for the accuracy specifications to apply. See the *Maintenance Section* on page 23 for re-zeroing instructions. PFA isolators are recommended for process temperatures higher than 40°C (104°F). For applications involving hydrofluoric acid (HF) with temperatures above 30°C (86°F), contact the factory for recommended materials of construction. For operation above 65°C (149°F), contact the factory. Positive system fluid pressure must be maintained at all times at elevated temperatures.

Effects of Fluid Viscosity and Specific Gravity

The flow controller has been factory calibrated using deionized water. Fluids with viscosities and/or specific gravity different from the calibration fluid (water) will cause slight accuracy errors. Correction factors for viscosity and specific gravity changes may be obtained from Entegris by visiting our website at: www.entegrisfluidhandling.com and following the Sensing and Controlling product links.

Unit Enclosure

The standard NT Integrated Flow Controller cover is factory sealed and should not be tampered with or opened. Spray-down or temporary immersion will not compromise the performance of the unit.

NOTE: Any attempt to remove, tamper with or open the flow controller cover will void the warranty.

Performance

Operating Line Pressure Requirements

For flow controllers with flow ranges 0–15 ml/min. to 0–1250 ml/min. (code TL to T4), the unit will operate within specifications at any inlet pressure within the range of 69–414 kPa (10–60 PSIG).

For flow controller with flow range of 0–2500 ml/min. (code T5), the unit will operate within specifications at any inlet pressure within the range of 83–414 kPa (12–60 PSIG).

- ! CAUTION:**
! The flow controller may be damaged if it is subjected to any level of vacuum pressure (less than atmospheric pressure).

Operating Pressure Drop Requirements

The flow rate is calculated using Entegris' differential pressure flow technology. For flow controllers with flow ranges 0–15 ml/min. to 0–1250 ml/min. (code TL to T4), the minimum pressure drop (inlet to outlet port differential pressure) required for the unit is 69 kPa (10 PSIG). For flow controllers with flow range of 0–2500 ml/min. (code T5), the minimum pressure drop (inlet to outlet port differential pressure) required for the unit is 83 kPa (12 PSIG).

For example, if a 0–125 ml/min. (code T1) flow controller is operating at an inlet pressure of 103 kPa (15 PSIG) and outputs the flow to a pressurized canister at 69 kPa (10 PSIG), the differential pressure available to the unit will only be 34 kPa (5 PSIG) [103 kPa (15 PSIG) inlet pressure minus 69 kPa (10 PSIG)

canister pressure]. This scenario does not meet the pressure drop requirement of 69 kPa (10 PSIG) for this unit and it may not perform within the specification. For this example, either increase the inlet pressure or decrease the canister pressure to obtain a 69 kPa (10 PSIG) pressure drop.

Flow Accuracy

The accuracy of the analog flow measurement is $\pm 1\%$ of full scale from 20–100% of the full scale flow range. The accuracy of the analog flow measurement is $\pm 2.5\%$ of full scale from 10–20% of the full scale flow range. The accuracy specification includes the effects of linearity, hysteresis and repeatability, using deionized water at 23°C (73°F). The accuracy between 0–10% of full scale flow range is not specified.

To meet the accuracy specification, a re-zero is required for every 10 PSIG (69 kPa) change in line pressure.

Response Time

Response time is defined as the length of time required for the unit's input signal and the unit's calculated output to match within the full scale flow accuracy specification. The typical response time is within two seconds.

The flow controller will accept setpoint changes within 50 milliseconds of receiving the new setpoint value.

When power is first applied to the unit, such as during a startup sequence, the calculated output will be controlled to within the full scale flow accuracy specifications within ten seconds.

Suspend Control Feature

Continuous controller type only:
The unit functions will be suspended when the setpoint is below 5% of the maximum setpoint controller signal (20 mA, 5 VDC or 10 VDC).

In this condition, the unit valve position is locked and the control is suspended. Locking the valve position allows for uncontrollable flow. This can be useful if constant flow for deionized water systems is required.

Pressure Accuracy

The accuracy of the analog pressure output is $\pm 1\%$ of full scale. These calculations include the effects of linearity, hysteresis and repeatability, measured at 23°C (73°F).

Temperature Increase at Unit Enclosure

You may notice a slight temperature increase of the unit cover while in an ambient environment after warm-up, when idling, or while controlling flow. This is normal.

Operational Reliability

Redundant Process Seals

All internal process wetted seals are redundant, i.e., there is a secondary seal that prevents process fluid from reaching the interior of the device in the case of a primary seal failure. Weep holes are provided from the secondary containment regions.

Drop and Topple

If the unit topples over from a 45-degree angle onto a bench top, the performance will not be compromised and the unit will not be externally damaged.

Cable Pull

The cable will withstand a static pull test of 9.1 kg (20 lbs.) straight and 4.5 kg (10 lbs.) at 90 degrees without being damaged.

Status and Alarming

Status

NT Integrated Flow Controller Model 6510 provides local status LEDs. The LED status codes are listed in Table 3 on page 20.

Alarming

A discrete 2-wire alarm relay output is provided. The factory preset alarms are DEVICE CRITICAL FAULT and RE-ZERO FAULT (see Table 3). There are no delay options for these two faults.

There are 3 alarm delays. These are Flow delay, P delay and SP delay. These are factory preset to 0 seconds. They can be programmed by the factory to the following ranges to meet the needs of the end user:

- Flow delay: 0–60 seconds
- P delay: 0–60 seconds
- SP delay: 0–60 seconds

Each individual alarm in Table 3 is tied to one of these three system level delay values and noted as such in the Trip Conditions column of Table 3. This value is applied commonly to all its associated alarms.

Before ordering, please consult the factory for options on configuring alarm relay outputs and alarm delays differently than the factory presets.

LED Status Codes

LED STATUS CODES

LED Indication Priority	State	Trip Conditions (settable parameters)	Clear Conditions (volatile with power cycle)	Alarm Condition and Indication					
				Alarm Relay		Alarm Relay		Color and Pattern	
				Enable Bit	Default	Enable Bit	Default	Mod LED	Sys LED
—	DEVICE OK	—	—	—	—	—	—	G	G
1	DEVICE CRITICAL FAULT	Diagnostic fault	Power cycle with fault resolved	Fixed on	Factory Enabled	Fixed on	Factory Enabled	R	R
2	RE-ZERO FAULT	Pressure (P1 or P2) outside limits 7- 414 kPa (1-60 PSIG) during zeroing	Successful re-zero cycle	Configurable	Factory Enabled	Configurable	Factory Enabled	G Off	Off Off
3	OVER PRESSURE (P1 > 414 kPa [60 PSIG])	Trip point = P1 > 100% (414 kPa [60 PSIG fixed]) Delay time = P delay P delay default = 0 Active w/both SP = 0 & SP ≠ 0 Will not trip on P2	Pressure P1 return to normal (after P delay)	Configurable	Disabled	Configurable	Factory Enabled	G Off	G Off
4	ZERO PRESSURE (P1 < 0 kPa [0 PSIG])	Trip point = P1 < 0% (0 kPa [0 PSIG fixed]) Delay time = P delay P delay default = 0 Only active with setpoint ≠ 0 Will not trip on P2	Pressure P1 return to normal (after P delay)	Configurable	Disabled	Configurable	Factory Enabled	G Off	Off G
5	UNDER PRESSURE (P1 < 62 kPa [9 PSIG])	Trip point = P1 < 15% (62 kPa [9 PSIG fixed]) Delay time = P delay P delay default = 0 Only active with setpoint ≠ 0 Will not trip on P2	Pressure P1 return to normal (after P delay)	Configurable	Disabled	Configurable	Factory Enabled	G Off G Off	Off Off G Off
6	SETPOINT NOT EQUAL TO FLOW	Delta = SP - flow Delay time = SP delay SP delay default = 0 Only active with setpoint ≠ 0	Flow return to normal (after SP delay)	Configurable	Disabled	Configurable	Disabled	R G	G G
7	FLOW HIGH	Trip point = Flow high Delay time = Flow delay (default = 0)	Flow return to normal (after Flow delay)	Configurable	Disabled	Configurable	Disabled	G Off	R Off
8	FLOW LOW	Trip point = Flow low Delay time = Flow delay (default = 0)	Flow return to normal (after Flow delay)	Configurable	Disabled	Configurable	Disabled	G Off	Off R
9	PRESSURE HIGH (P1 > PressTrip-PointHigh)	Trip point = P1 high Delay time = P delay P delay default = 0 Only P1 activates alarm	Pressure P1 return to normal (after P delay)	Configurable	Disabled	Configurable	Disabled	G Off	R G
10	PRESSURE LOW (P1 < PressTrip-PointLow)	Trip point = P1 low Delay time = P delay P delay default = 0 Only P1 activates alarm	Pressure P1 return to normal (after P delay)	Configurable	Disabled	Configurable	Disabled	G Off	R R

P=Pressure P1=Inlet pressure signal P2=Other pressure signal SP=Setpoint G=Green R=Red

Table 3. LED status codes

Diagnostic Guide

Symptom	Possible Causes	Suggestions
1. Flow output reads 4 mA when fluid flow is present.	The unit is installed backwards.	Install the unit so the inlet flow is plumbed on the same side as the electrical connection and flow is in the direction of the arrow.
	Insufficient line pressure/insufficient pressure drop.	Verify the inlet pressure is adequate as described in the <i>Operating Line Pressure Requirements</i> on page 18. Verify the pressure drop meets the requirements according to the <i>Operating Pressure Drop Requirements</i> on page 18.
	The unit needs to be re-zeroed	Perform the re-zeroing procedure.
2. Flow output reads above 4 mA when there is zero flow.	The unit needs to be re-zeroed.	Perform the re-zeroing procedure.
3. Flow output does not change with changing flow.	The pressure output is being monitored instead of the flow output.	Check the wiring to ensure the flow output is wired correctly.
4. Current output is extremely high (>25 mA).	The incorrect wires are connected to the flow monitoring device.	Confirm wiring. Wire functions are printed on the unit label.
	The 4–20 mA flow signal is shorted to power (+24 V).	Examine all electrical connections. Please note, if wires are stripped back too far before insertion in a terminal block, they may cross and short together.
5. Flow output is extremely noisy (spiking above and below 20 and 4 mA).	The actual fluid flow conditions are noisy.	Flow turbulence may be caused by "noisy" pumps used in a system. Examples of noisy pumps are diaphragm pumps without pulsation dampeners and peristaltic pumps operating at low flow rates. Please contact Entegris for additional information.
	The supply power (+24 V) is noisy.	If the power supply is shared with other systems, components such as solenoids, DC motors, valves, etc., the unit may be receiving "dirty" power. The noise spikes on the power supply will cause the unit output to be noisy or cause the unit to enter a reset mode.

Diagnostic Guide (*continued*)

Symptom	Possible Causes	Suggestions
6. Flow output does not correspond to setpoint for high flow rates.	Insufficient line pressure/ insufficient pressure drop.	Verify the inlet pressure is adequate as described in the <i>Operating Line Pressure Requirements</i> on page 18. Verify the pressure drop meets the requirements according to the <i>Operating Pressure Drop Requirements</i> on page 18.
	Viscosity and specific gravity offsets.	Correct for viscosity and specific gravity.
7. Flow rate is not meeting desired setpoint within 10 seconds or longer.	The unit is receiving a setpoint signal with no fluid flow present. The unit valve is moved to the full-open position. Depending upon flow range, the unit may require 10-15 seconds or more to move from the full-open position to the correct setpoint position.	Do not send a setpoint signal to the unit when no fluid flow is available. (see Symptom 6)
	Insufficient line pressure/ insufficient pressure drop.	Verify the inlet pressure is adequate as described in the <i>Operating Line Pressure Requirements</i> on page 18. Verify the pressure drop meets the requirements according to the <i>Operating Pressure Drop Requirements</i> on page 18.
8. Flow output is not responsive to changes in setpoint signal.	Incorrect wiring of setpoint signal.	Review <i>Wiring Diagram</i> on page 13. Ensure the ground connections are connected properly. Confirm the presence of the setpoint signal. Confirm the unit is configured for the proper setpoint signal (i.e. 4–20 mA, 0–5 VDC, 0–10 VDC) by reading part number on the label.
	Valve in full open position. If the unit is plumbed between two closed valves, the unit may stall in the full open position when the unit is commanded to close. Since a fixed volume of fluid is incompressible, the unit may stall when attempting to close if upstream and downstream valves are closed.	Avoid conditions of simultaneously closed valves upstream and downstream of the unit. The unit can be returned to normal operation by performing a re-zero or by cycling power.
9. Unit not responding to a setpoint.	24 VDC is continuously applied to 9-Green/Pin J re-zero input line.	Re-zero input line should only be energized when re-zero is needed.

Maintenance

Normal Operation

During normal operation, the standard NT Integrated Flow Controller requires no maintenance, other than a periodic re-zero of the unit.

Re-zero Function

The no-flow calibration of the flow controller can be re-zeroed, meaning that the flow output that corresponds to zero flow may be reset.

NOTE: When executing the re-zero function, there must be between 7–414 kPa (1–60 PSIG) of static pressure.

NOTE: The following procedure must be followed precisely to ensure proper flow controller re-zero.

1. The unit re-zero function requires the same power supply of 24 VDC \pm 10%.
2. Using the pressure signal of the unit, verify that there is stable static line pressure of between 7–414 kPa (1–60 PSIG). Optimum pressure for re-zero is the operation pressure, typically greater than 69 kPa (10 PSIG) or 83 kPa (12 PSIG). **There must be at least 7 kPa (1 PSIG) of stable static line pressure.**
3. Apply 24 VDC \pm 10% to the 9-Green/Pin J wire for the desired re-zero time. Suggested minimum is 10 seconds; absolute minimum is 4 seconds. The longer the re-zero process is active, the better the zero value will be for flow output. The 24 VDC for re-zero must have the same ground as the ground 8-Black/Pin E wire. Do not continuously apply 24 VDC to this 9-Green/Pin J wire.

In most applications, the re-zero procedure may be automated using switches, a PLC or other logic controller devices.

When the re-zero function is activated, the flow controller valve module will close fully to ensure that fluid is not flowing. The unit will verify the no-flow condition, and then re-zero the flow module. The re-zero function is completed when 24 VDC is disconnected from 9-Green/Pin J.

In order to obtain best performance, the re-zero function should be performed, at minimum if possible, once per day when operating at ambient temperature conditions. The re-zero function should be performed more often if operating at higher temperature. It is also recommended to perform a re-zero after startup and after fluid temperature changes of greater than 5°C (9°F). Best performance will be achieved by re-zeroing between each dispense cycle.

Automatic Re-zero (Auto-zero)

For flow controllers configured as batch controllers, the re-zero function is automatic. Batch controllers will automatically re-zero when the setpoint is below 5% of full scale for longer than two seconds after the valve closes and the line pressure is from 7–414 kPa (1–60 PSIG). Of course, units configured in batch mode may be manually re-zero (as discussed above) at any time.

Auto-zero applies to the flow module only. The manual re-zero will zero the flow module and valve position.

Reference

Physical Specifications

Materials:	Wetted parts	Body	PTFE
		Diaphragms	PTFE
		Sensor interface	PFA or CTFE
		O-rings	Kalrez® 4079, 1050LF or 6375 UP
	Nonwetted parts	PTFE, polypropylene, Viton®, PVDF, polyurethane, nylon	
Connection type:	Flaretek tube fitting		
Enclosure:	IP64		

Electrical Specifications

Input voltage:	24 VDC \pm 10% regulated
Input current:	1.0 A nominal, 1.2 A peak
Impedance of setpoint input (voltage):	37 kOhm
Voltage drop, current setpoint input:	<4.6 Volts at 20 mA at 230 ohm
Lift-off voltage for current loops:	12 VDC
Load effect on 4–20 mA outputs:	R _{Load} 0–600 ohms, no effect
Electrical connection:	6', 12', 30' FEP-jacketed or PVC-jacketed cable

Performance Specifications

Flow accuracy:	\pm 1.0% full scale from 20–100% of full scale and \pm 2.5% from 10–20% of full scale Accuracy not specified from 0–10% of full scale Calibrated using deionized water at 23°C (73°F)
Pressure accuracy:	\pm 1.0% full scale (full scale is 414 kPa [60 PSIG])
Repeatability:	0.5% full scale from 20–100% of full scale 1.0% full scale from 10–20% of full scale
Response time:	<2 seconds from 10–95% of full scale flow range at 207 kPa (30 PSIG) <3 seconds from 0 to control band at 207 kPa (30 PSIG)
Process temperature:	10–65°C (50–149°F) for Code P1 and P2 10–35°C (50–95°F) for Code P5
Storage temperature:	-40–65°C (-40–149°F)
Operating pressure:	69–414 kPa (10–60 PSIG) for Code TL–T4 83–414 kPa (12–60 PSIG) for Code T5
Over-pressure limit:	690 kPa (100 PSIG)

NOTE: Specifications are subject to change without notice. Please consult the factory for the most current information.

Ordering Information

The part number represents the configuration. For example, part number 6510-T2-F02-V06-K-P1-U1 represents the following configuration:

- NT Integrated Flow Controller, Model 6510
- Flow range of 0 – 250 ml/min.
- ¼" Flaretek tube fitting
- 6' pigtail PVC-jacketed electrical cable
- 4 – 20 mA setpoint input, batch type
- CTFE sensor interfaces
- Kalrez 4079/Viton for primary/secondary seal

The flow controller is available in the following fitting size and flow range combinations:

Code	TL	TT	T0	T1	T2	T3	T4	T5
¼" F02	Yes	Yes	Yes	Yes	Yes	Yes	Yes	–
¾" F03	Yes	Yes	Yes	Yes	Yes	Yes	Yes	Yes
½" F04	–	–	–	–	–	Yes	Yes	Yes

Code	Flow Range
TL	0–15 ml/min.
TT	0–25 ml/min.
T0	0–50 ml/min.
T1	0–125 ml/min.
T2	0–250 ml/min.
T3	0–500 ml/min.
T4	0–1250 ml/min.
T5	0–2.5 l/min.

Ordering Information (*continued*)

Code	Inlet/Outlet Type
F02	1/4" Flaretek tube fitting
F03	3/8" Flaretek tube fitting
F04	1/2" Flaretek tube fitting

Code	Electrical Connector Type
B06	FEP-jacketed 6' pigtail electrical cable
B12	FEP-jacketed 12' pigtail electrical cable
B30	FEP-jacketed 30' pigtail electrical cable
V06	PVC-jacketed 6' pigtail electrical cable
V12	PVC-jacketed 12' pigtail electrical cable
V30	PVC-jacketed 30' pigtail electrical cable
G06	14-pin Turck connector with 6' PVC-jacketed electrical cable
G12	14-pin Turck connector with 12' PVC-jacketed electrical cable
G30	14-pin Turck connector with 30' PVC-jacketed electrical cable

Code	Setpoint Input Signal, Controller Type
A	4–20 mA, continuous
B	0–10 VDC, continuous
C	0–5 VDC, continuous
K	4–20 mA, batch
L	0–10 VDC, batch
M	0–5 VDC, batch

Code	Sensor Interface
P1	CTFE
P2	PFA
P5	CTFE (hydrofluoric acid compatible)

Code	Primary/Secondary Seal
U1	Kalrez 4079/Viton
U2	Kalrez 1050 LF/Viton
U3	Kalrez 6375 UP/Viton

ACCESSORIES

Part Number	Description
14G02	2 meter mating cable, 14 pin Turck to pigtail, PVC-jacketed
14G05	5 meter mating cable, 14 pin Turck to pigtail, PVC-jacketed
14G10	10 meter mating cable, 14 pin Turck to pigtail, PVC-jacketed

Certifications

CE Compliance

Entegris Inc. products are designed and tested to meet the most current CE requirements. Please visit www.entegrisfluidhandling.com for the most current information.

Warranty

Entegris Standard Warranties

GENERAL LIMITED WARRANTY FOR NON-CUSTOM ENTEGRIS PRODUCTS

Subject to the limitations and disclaimers set forth below, Entegris, Inc. ("Entegris") warrants that for the Applicable Warranty Period (as defined in the section entitled "Applicable Warranty Period" below) following the date of shipment, the products manufactured by it shall be free of defects in materials and workmanship when installed, used, serviced and operated in accordance with the applicable product documentation. The Applicable Warranty Period does not apply to any lifetime performance. In the event that a product failure is caused by a defect in materials or workmanship within the Applicable Warranty Period, Entegris agrees to repair or replace, at its option and at no charge to the purchaser, any product or part thereof that proves to have such a defect, provided that prompt written notice of any such defect is given to Entegris. Entegris' agreement to repair or replace any product found to be defective in materials or workmanship is the exclusive remedy provided herein; this remedy shall not be deemed to have failed of its essential purpose so long as Entegris is willing and able to repair or replace any such defective Entegris product or part or to refund the purchase price paid.

Limitations

The warranty set forth above is LIMITED and does not cover: **(A)** products with the identification label or serial number altered or removed; **(B)** products which have been repaired, or tampered with or serviced by any person other than an authorized Entegris service representative; **(C)** products which have been subjected to misuse, neglect or abuse (including, without limitation, exposure to overpressure, use with excessive voltage or inappropriate power source or exposure to hostile operating conditions unless the product has been expressly specified by Entegris for use therein). In the case of Entegris products which are systems that include components manufactured by companies other than Entegris or its affiliates, the foregoing warranty shall apply only to those components and subassemblies manufactured by Entegris or its affiliates; the non-Entegris components and subassemblies included in such systems are covered by the warranty, if any, extended by the manufacturer thereof. Entegris hereby assigns any such warranty to the system purchaser.

Disclaimers

ENTEGRIS MAKES NO OTHER WARRANTY, EXPRESSED OR IMPLIED. THERE IS NO WARRANTY OF MERCHANTABILITY OR OF FITNESS FOR A PARTICULAR PURPOSE. THE APPLICABLE WARRANTY PERIOD IS NOT A LIFETIME PERFORMANCE WARRANTY. The warranty provided herein and the data, specifications and descriptions of Entegris products appearing in Entegris' published catalogs and product literature may not be altered except by express written agreement signed by an officer of Entegris. Representations, oral or written, which are inconsistent with this general limited warranty or any such publications are not authorized and if given, should not be relied upon. Notwithstanding the failure of any remedy provided herein, **in no event shall Entegris be liable for consequential, incidental, special or any other indirect damages resulting from economic loss or property damage sustained by any customer from the use of Entegris products.**

In the event of a breach of the foregoing warranty, Entegris' sole obligation shall be to repair or replace, at its option, any product or part thereof that proves defective in materials or workmanship within the warranty period, provided the customer notifies Entegris promptly of any such defect. The exclusive remedy provided herein shall not be deemed to have failed of its essential purpose so long as Entegris is willing and able to repair or replace any nonconforming Entegris product or part or to refund the purchase price paid.

Applicable Warranty Period

As used in this General Limited Warranty the term Applicable Warranty Period for the indicated product groups are as follows:

Warranty (*continued*)

Entegris Products	Warranty Period	Entegris Product Codes
Polymeric membrane products Exceptions: Does not apply to membrane-based purifiers	1 year from date of shipment	H4, H5, M4, M6
Metal membrane products Exceptions: Nickel membrane gas filtration products	2 years from date of shipment	I2
Exceptions: Nickel membrane gas diffuser products	5 years or 100,000 cycles (whichever comes first) from date of shipment	I2
Exceptions: Nickel membrane gas diffuser products	5 years or 100,000 cycles (whichever comes first) from date of shipment	I5
Polymeric membrane-based purifiers / Other liquid purifiers / Gas purifiers / Chemical filters	1 year from date of shipment	I7, I8, F1, F2, F4
Dispense products and liquid subsystems Exceptions: Products and subsystems purchased by Original Equipment Manufacturers (OEM)	1 year from date of shipment 18 months from date of shipment	H6 H6

Entegris Products	Warranty Period	Entegris Product Codes
Non-dispense electromechanical products	1 year from date of shipment	—
Integrated shipping systems products	30 days from date of shipment	—
Wafer handling, electronic packaging products and cleaning systems	90 days from date of shipment	—
Liquid fittings, containers and housings Exceptions: Sheetlined chemical container products and FluoroPure® PFA Liners (blistering, cracking or leakage only)	1 year from date of shipment 18 months from date of shipment	— —
Exceptions: FluoroPure® o-rings and gasket materials	90 days from date of shipment	—
Software Products	1 year from date of shipment	—
Other Products	1 year from date of shipment	—

CUSTOM ORDER LIMITED WARRANTY FOR ENTEGRIS PRODUCTS

Entegris, Inc. warrants Custom Order products against defects in materials and workmanship for a period of thirty (30) days following receipt by the purchaser. Entegris' sole obligation shall be to repair or replace, at its option, any Custom Order product that proves to be defective in materials or workmanship within the warranty period.

Disclaimers

ENTEGRIS MAKES NO OTHER WARRANTY, EXPRESSED OR IMPLIED. THERE IS NO WARRANTY OF MERCHANTABILITY OR OF FITNESS FOR A PARTICULAR PURPOSE. THE APPLICABLE WARRANTY PERIOD IS NOT A LIFETIME PERFORMANCE WARRANTY. The warranty provided herein and the data, specifications and descriptions of Entegris products appearing in Entegris' published catalogs and product literature may not be altered except by express written agreement signed by an officer of Entegris. Representations, oral or written, which are inconsistent with this general limited warranty or any such publications are not authorized and if given, should not be relied upon. Notwithstanding the failure of any remedy provided herein, **in no event shall Entegris be liable for consequential, incidental, special or any other indirect damages resulting from economic loss or property damage sustained by any customer from the use of Entegris products.**

In the event of a breach of the foregoing warranty, Entegris' sole obligation shall be to repair or replace, at its option, any product or part thereof that proves defective in materials or workmanship within the warranty period, provided the customer notifies Entegris promptly of any such defect. The exclusive remedy provided herein shall not be deemed to have failed of its essential purpose so long as Entegris is willing and able to repair or replace any nonconforming Entegris product or part or to refund the purchase price paid.

Repair and Warranty Service

Repair and warranty service is available at the Entegris factory. To expedite the return and repair of the product, contact Entegris at +1 800-394-4084. A Return Materials Authorization (RMA) number, MSDS requirements and a product packaging and return procedure will be provided at that time.

If the product being returned was exposed to a hazardous substance, a copy of the Material Safety Data Sheet (MSDS) for each hazardous substance identified must be included with the returned product.



WARNING! Mishandling products exposed to a hazardous substance may result in death or serious injury.

Technical Support

For technical support, contact the factory at +1 800-394-4084. Please have the complete model number, chemical and application information ready when calling.

ENTEGRIS, INC.

Corporate Headquarters

3500 Lyman Boulevard

Chaska, Minnesota 55318 USA

Customer Service Tel. +1 763-502-0200

Toll Free 877-503-0200

Customer Service Fax +1 763-502-0300

www.entegris.com

www.entegrisfluidhandling.com

Entegris,® NT® and Flaretek® are registered trademarks of Entegris, Inc.

versafast® is a registered trademark of Turck, Inc.

Kalrez® and Viton® are registered trademarks of DuPont Dow Elastomers, L.L.C.

©2008 Entegris, Inc.

Printed in USA

P/N 2912 (Rev. A 11/08)

3963-5374MAX-1108