



WAFERGARD® W-SEAL SURFACE-MOUNT GAS FILTERS

All-metal W-seal gas filters for ultrapure surface-mount applications

Overview

Wafergard® W-Seal Mini filters provide the industry's best filter in a surface-mount design. Available with stainless steel or nickel filter elements, the filters provide ultimate process protection, superior corrosion resistance and excellent compatibility with inert, hydride and reactive gases.*

Surface-mount gas filter designs consume less space on gas panels than standard in-line designs, while reducing parts inventories and variations.

*Nickel filters are not recommended for use with CO, O₃ and low-level hydride dopant gases.

Key Features

- Manufactured in a world-class, ISO 9001, cleanroom facility
- Superior corrosion resistance
- Excellent compatibility with inert, hydride and reactive gases
- Superior downstream cleanliness

Specifications

Materials:	Stainless steel membrane or patented, sintered nickel membrane	
	Housing, base block and end cap	316L double-melt stainless steel
Particle retention:	Nickel filters	Greater than 99.9999999% removal of all particles (referenced at the most penetrating particle size)
	Stainless steel filters	Greater than 99.9999% removal of all particles (referenced at the most penetrating particle size)
Downstream cleanliness:	Particles	Less than 0.03 particles/liter (<1 particle/ft ³) greater than 0.01 μm
	Volatiles	Volatile outgassing of H ₂ O, O ₂ and THC is below detectable limits (by RGA and FID at room temperature)
Operating conditions:	Maximum operating pressure	1 MPa (10 bar, 145 PSID)
	Maximum forward/reverse differential pressure	1 MPa (10 bar, 145 PSID)
	Maximum operating temperature	400°C (752°F)
Removal rating:	≥0.003 μm	
Surface finish interior:	≤5 μin Ra	
Helium leak rating:	Qualified	2 × 10 ⁻¹⁰ cc/min.
	Tested	1 × 10 ⁻⁹ cc/min.



Applications

- Ultrapure gas lines
- High-temperature applications
- Dynamic-pressure applications
- Stainless steel filters for inert, hydride and CO gases; nickel filters for inert and reactive gases

Dimensions

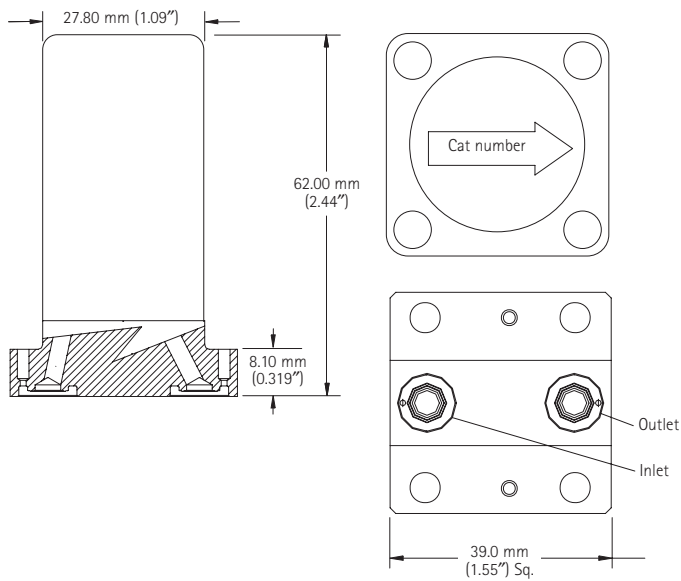

Ordering Information

Part Number	Description
WG2 S01 WW2	Wafergard® W-Seal Mini filter, stainless steel
WG3 SS1 WW2	Wafergard® W-Seal Mini filter, nickel

For More Information

Please call your Regional Customer Service Center today to learn what Entegris can do for you. Visit www.entegris.com and select "Regional Customer Service Centers" for the center nearest you.

Terms and Conditions of Sale

All purchases are subject to Entegris' "Terms and Conditions of Sale." To view and print this information, visit Entegris' website at www.entegris.com and select the Legal Notices link from the footer found on the home page.

Performance Data

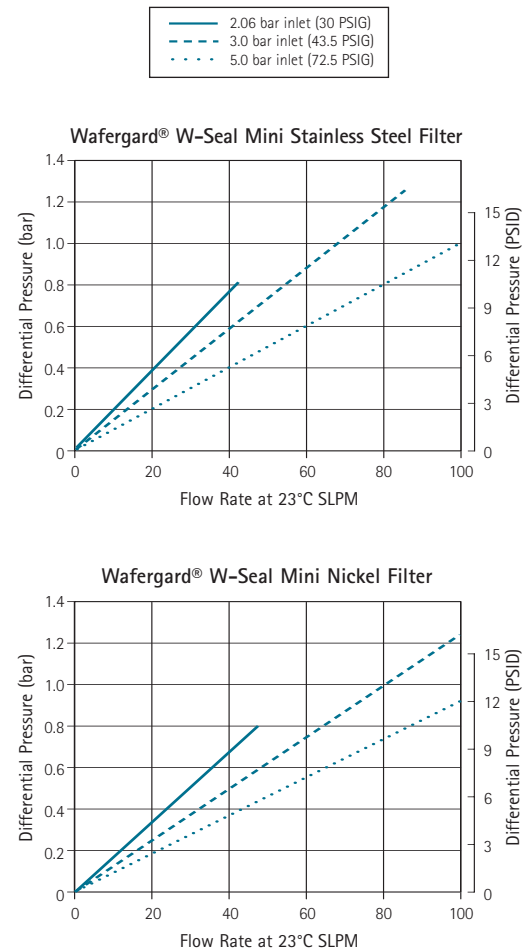

Entegris® and Wafergard® are registered trademarks of Entegris, Inc.

ENTEGRIS, INC.

Corporate Headquarters / 3500 Lyman Boulevard / Chaska, Minnesota 55318 USA
 Customer Service Tel. 952-556-4181 / Customer Service Fax 952-556-8022
www.entegris.com