



WAFERGARD® GN GAS FILTER GUN

Easy-to-use, lightweight POU gas filter

Overview

The Entegris Wafergard® GN gas filter gun is designed for point-of-use filtration of compressed gas. The filter element is an exclusive Entegris design and provides these significant advantages:

Superior Durapore® Membrane

The hydrophobic Durapore PVDF membrane in the Wafergard GN filter element is rated for 0.003 µm particle retention in gas applications. In addition, the unique properties of the membrane eliminate particle shedding.

High Effective Filtration Area

The Wafergard GN filter element provides 10 cm² of effective filtration area. This increased surface area results in higher flow rates, more effective wafer cleaning and less frequent changeout.

Reliable Performance

The Wafergard GN filter element is manufactured in a clean environment and is 100% pretested and preflushed to assure reliable performance.

Corrosion Resistance

The white nylon design of the filter gun makes it resistant to corrosion in acid and most solvent environments.

Ordering Information

Part Number	Description
WGGB 01 KAN	Wafergard GN gas filter gun
WGFG 01 KLO	Wafergard GN gas filter, 10/pk
P03203J	Trigger repair kit (includes 1 trigger, 1 spring and 1 o-ring)
XX67 000 WH	Polyurethane tubing with fitting, 2.1 m/7 ft.



Dimensions

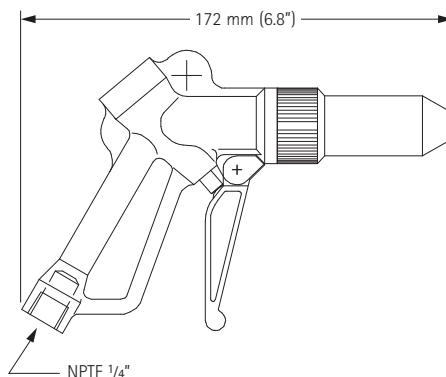

Specifications

Materials:	Gun	Body, trigger	White nylon-molded body
		Valve system	Stainless steel 304
		O-ring	EPDM
		Tubing	Polyurethane
Cartridge filter		Membrane	Polypropylene hydrophobic Durapore PVDF
		Shell, support	Polypropylene
Operating conditions:	Maximum forward differential pressure	0.4 MPa at 20°C (68°F)	
	Maximum reverse differential pressure	0.03 MPa at 20°C (68°F)	
	Maximum operating temperature with filter	50°C (122°F)	
Weight:	Approx. 150 g (5.29 oz.)		
Connections:	Filter gun	1/4" NPTF inlet NPT female	
Particle retention:	0.01 µm		
Retention:	Greater than 99.9999999% removal of all particles (referenced at the most penetrating particle size)		

Performance Data

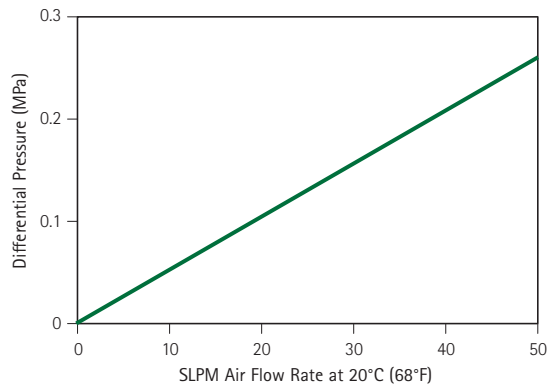

For More Information

Please call your Regional Customer Service Center today to learn what Entegris can do for you. Visit www.entegris.com and select the "Customer Service" link for the center nearest you.

Terms and Conditions of Sale

All purchases are subject to Entegris' "Terms and Conditions of Sale." To view and print this information, visit Entegris' website at www.entegris.com and select the Legal Notices link from the footer found on the home page.

Entegris®, Mykrolis® and Wafergard® are registered trademarks of Entegris, Inc. Durapore® is a registered trademark of Millipore Corporation.

ENTEGRIS, INC.

Corporate Headquarters / 3500 Lyman Boulevard / Chaska, Minnesota 55318 USA
 Customer Service Tel. +1 952-556-4181 / Customer Service Fax +1 952-556-8022
www.entegris.com