



MOISTURE (H₂O) REMOVAL EFFICIENCY FOR AERONEX® Z2 PURIFIER TEST REPORT

Purpose

The purpose of this test was to measure the 100 pptv (parts-per-trillion-by-volume) moisture breakthrough time of the Entegris Aeronex® Z2 series purifier. Herein, data for moisture removal by the Aeronex Z2 purifier to <100 pptv in N₂ (nitrogen) gas is shown.

Test Methodology

An activated Aeronex Z2 series purifier was tested for 100 pptv moisture breakthrough time in N₂ gas. The experimental test method involves a quadrupole-based APIMS (Atmospheric Pressure Ionization Mass Spectrometry) that can detect moisture at <100 pptv level. A moisture challenge of 24.7 ppmv H₂O in N₂ gas was sent through the purifier.

Results

The APIMS ion signal corresponding to moisture (m/z = 18) monitored at the Aeronex Z2 purifier outlet as a function of time under a 24.7 ppmv challenge shows <100 pptv outlet purity.

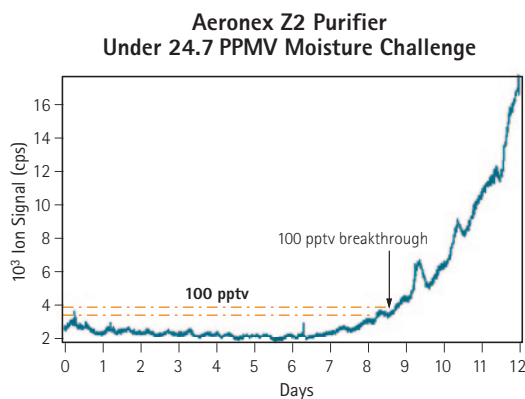

Test Conditions

INSTRUMENT

Type	Positive ion APIMS
Manufacturer	Extrel
Model	Atto-Spec 1
LDL	<100 pptv in N ₂

PARAMETERS

Purifier series	Aeronex Z2
Purifier size	70K
Gas tested	Wet N ₂
Zero gas source	Dry N ₂
Challenge source	Calibrated H ₂ O bubbler
Pressure	94 PSIG
Flow rate	7.8 SLPM
Temperature	Room temperature

INLET CHALLENGE

Contaminant	Moisture
Level	24.7 ppmv

RESULTS

Contaminant	24.7 ppmv H ₂ O in N ₂
Final measurement	<100 pptv H ₂ O in N ₂

Test Manifold

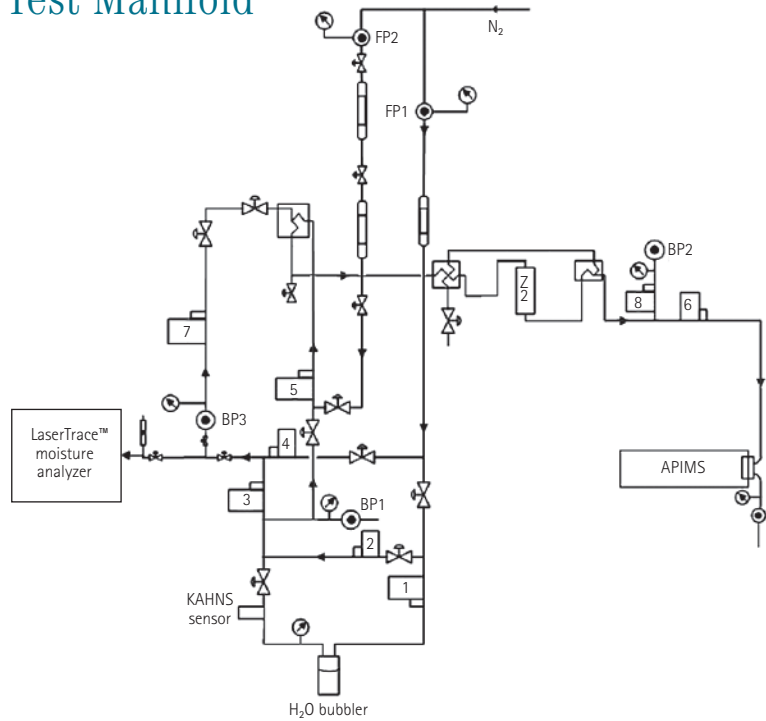

Mass flow controller: 1 = 50 SCCM, 2 = 30 SLM, 4 = 2 SLM, 6 = 5 SLM, 7 = 50 SCCM, 8 = 5 SLM			
Diaphragm valve	FP = Forward pressure	"1" purifier	Aeronex Z2 = Test purifier, 70K
Pressure regulator	BP = Back pressure	Rotameter	

For More Information

Please call your Regional Customer Service Center today to learn what Entegris can do for you. Visit www.entegris.com and select the "Customer Service" link for the center nearest you.

Terms and Conditions of Sale

All purchases are subject to Entegris' "Terms and Conditions of Sale." To view and print this information, visit Entegris' website at www.entegris.com and select the Legal Notices link from the footer found on the home page.

Entegris® and Aeronex® are registered trademarks of Entegris, Inc.
LaserTrace™ is a trademark of Tiger Optics, LLC.

ENTEGRIS, INC.
Corporate Headquarters | 3500 Lyman Boulevard | Chaska, Minnesota 55318 USA
Customer Service Tel. +1 952-556-4181 | Customer Service Fax +1 952-556-8022
www.entegris.com