

GateKeeper® GPU TX Media Gas Purifiers

Superior purity control

Entegris' GateKeeper® GPU gas purifiers were designed to improve purity consistency, lifetime, and final purity in microelectronics applications where high-purity gas is critical. Leveraging our expertise in material science, we have developed a new generation of TX gas purification products that deliver unsurpassed value and performance.



APPLICATIONS

- Semiconductor
- LED
- Data storage
- Solar
- Flat panel display

FEATURES & BENEFITS

Process control and protection	Purity control below part-per-billion (ppb) levels Low pressure drop through the purifier CE certified to the Pressure Equipment Directive (PED) Manufactured in an ISO® 9001:2015 facility
Cost effective	Regenerable – eliminates disposal issues and costs Long lifetime – improves cost of ownership
Safe and simple to use	Uses ambient temperature purification – no heat or power required to operate Insensitive to orientation (horizontal/vertical)

GENERAL SPECIFICATIONS

Gases purified	CDA, O ₂ , N ₂ , Ar, He, Ne, Kr, Xe, H ₂ , CO ₂ , C ₂ H ₆ , C ₃ H ₈ , C ₄ H ₁₀ , C ₂ H ₂ , C ₃ H ₆ , C ₂ H ₄	
Impurities removed	CONTAMINANTS	OUTLET PURITY
	Condensable Organics >C6	<1 pptV
	Non-condensable Organics >C3	< 5 pptV
	Refractory compounds (as HMDSO)	<1 pptV
	C ₃ H ₇ NO (DMF)	<100 pptV
Outlet particle filter	Wafergard® — 316 stainless steel membrane, 20 µm or 0.003 µm	
Lifetime	<p>One year with 1 ppm inlet challenge of toluene with flow rates shown on the next page.</p> <p>The lifetime varies with the inlet impurities and flow rate. Contact Entegris for application specific lifetime calculations.</p>	
Regenerable	Yes	
Dangerous goods (DG)	No	
Operating temperature	0° – 65°C (32° – 149°F)	
Leak rating	1 × 10 ⁻⁹ atm cc/sec of He	
Materials of construction	Housing: 316L stainless steel	
Certification	<p>CE certified to the Pressure Equipment Directive (PED)</p> <p>Designed in accordance with ASME®</p>	

OPERATING SPECIFICATIONS

Model	Maximum flow rate	Lifetime is 1 year at this flow rate, with 1 ppm toluene	Maximum operating pressure – purifier only	Maximum operating pressure – purifier with options	Pressure drop, with 20 µm particle filter*	Pressure drop, with 0.003 µm particle filter*
GPU 15	0.5 slpm	0.3 slpm	2,000 psig	250 psig	–	1.0 psid
GPU 35	1 slpm	0.5 slpm	1,400 psig	250 psig	–	0.3 psid
GPU 70	5 slpm	4.0 slpm	1,400 psig	250 psig	–	0.5 psid
GPU 80	10 slpm	5.0 slpm	1,400 psig	250 psig	–	1.0 psid
GPU 100	20 slpm	7.4 slpm	1,000 psig	250 psig	–	16.7 psid
GPU 200	20 slpm	12.0 slpm	800 psig	250 psig	–	0.7 psid
GPU 300	50 slpm	18.0 slpm	800 psig	250 psig	–	1.3 psid
GPU 500	75 slpm	36.0 slpm	600 psig	250 psig	–	1.3 psid
GPU 700	120 slpm	50.0 slpm	600 psig	250 psig	–	1.8 psid
GPU 2500 4R	300 slpm	170.0 slpm	505 psig	250 psig	–	5.0 psid
GPU 2500 8R	500 slpm	170.0 slpm	505 psig	250 psig	–	5.6 psid
GPU 3000	500 slpm	200.0 slpm	505 psig	250 psig	–	5.6 psid
GPU 5000	500 slpm	320.0 slpm	505 psig	250 psig	–	7.0 psid
GPU 10M 8R	1,000 slpm	640.0 slpm	370 psig	250 psig	–	5.8 psid
GPU 10M 12R	1,000 slpm	640.0 slpm	370 psig	250 psig	–	8.0 psid
GPU 13M 12R	2,000 slpm	820.0 slpm	370 psig	250 psig	2.0 psid	–
GPU 13M 16R	2,500 slpm	820.0 slpm	370 psig	250 psig	3.0 psid	–
GPU 17M 12R	2,000 slpm	1,020.0 slpm	370 psig	250 psig	2.0 psid	–
GPU 17M 16R	2,500 slpm	1,020.0 slpm	370 psig	250 psig	3.0 psid	–
GPU 20M 12R	2,000 slpm	1,260.0 slpm	370 psig	250 psig	–	19.0 psid
GPU 20M 16R	2,500 slpm	1,260.0 slpm	370 psig	250 psig	–	19.0 psid

*Purifier only at maximum flow rating with 90 psig inlet pressure

FACILITY SPECIFICATIONS

GPU model	Connection size (VCR)	Inlet/outlet connection type (VCR)	Outside Diameter (OD)	Overall length (OAL)	Approximate weight
GPU 15	¼"	Male/male	25.4 mm (1.0")	84 mm (3.3")	0.2 kg (0.4 lbs)
GPU 35	¼"	Male/male	38.1 mm (1.5")	84 mm (3.3")	0.3 kg (0.7 lbs)
GPU 70	¼"	Male/male	38.1 mm (1.5")	114 mm (4.5")	0.3 kg (0.7 lbs)
GPU 80	¼"	Male/male	38.1 mm (1.5")	127 mm (5.0")	0.3 kg (0.7 lbs)
GPU 100	¼"	Male/male	N/A	84 mm (3.3")	0.9 kg (2.0 lbs)
GPU 200	¼"	Male/male	50.8 mm (2.0")	157 mm (6.2")	0.9 kg (2.0 lbs)
GPU 300	¼"	Male/male	50.8 mm (2.0")	208 mm (8.2")	1.1 kg (2.5 lbs)
GPU 500	¼"	Male/male	76.2 mm (3.0")	201 mm (7.9")	1.8 kg (4.0 lbs)
GPU 700	¼"	Male/male	76.2 mm (3.0")	254 mm (10.0")	2.5 kg (5.5 lbs)
GPU 2500 4R	¼"	Male/male	101.6 mm (4.0")	439 mm (17.3")	6.8 kg (15 lbs)
GPU 2500 8R	½"	Male/male	101.6 mm (4.0")	445 mm (17.5")	6.8 kg (15 lbs)
GPU 3000	½"	Male/male	101.6 mm (4.0")	508 mm (20.0")	7.3 kg (16 lbs)
GPU 5000	½"	Male/male	101.6 mm (4.0")	785 mm (30.9")	10.0 kg (22 lbs)
GPU 10M 8R	½"	Male/male	152.4 mm (6.0")	737 mm (29.0")	20 kg (44 lbs)
GPU 10M 12R	¾"	Male/male	152.4 mm (6.0")	749 mm (29.5")	21.8 kg (48 lbs)
GPU 13M 12R	¾"	Male/male	152.4 mm (6.0")	892 mm (35.1")	24.9 kg (55 lbs)
GPU 13M 16R	1"	Male/male	152.4 mm (6.0")	899 mm (35.4")	24.9 kg (55 lbs)
GPU 17M 12R	¾"	Male/male	152.4 mm (6.0")	1085 mm (42.7")	29.5 kg (65 lbs)
GPU 17M 16R	1"	Male/male	152.4 mm (6.0")	1090 mm (42.9")	29.5 kg (65 lbs)
GPU 20M 12R	¾"	Male/male	152.4 mm (6.0")	1290 mm (50.8")	34 kg (75 lbs)
GPU 20M 16R	1"	Male/male	152.4 mm (6.0")	1296 mm (51.0")	34 kg (75 lbs)

FACILITY SPECIFICATIONS, PURIFIERS WITH ISOLATION VALVES

GPU model	Connection size (VCR)	Inlet/outlet connection type (VCR)	Outside Diameter (OD)	Overall length (OAL) with valves	Approximate weight with valves
GPU 15	¼"	Female/female	25.4 mm (1.0")	234 mm (9.2")	1.1 kg (2.4 lbs)
GPU 35	¼"	Female/female	38.1 mm (1.5")	234 mm (9.2")	1.2 kg (2.6 lbs)
GPU 70	¼"	Female/female	38.1 mm (1.5")	264 mm (10.4")	1.3 kg (2.9 lbs)
GPU 80	¼"	Female/female	38.1 mm (1.5")	277 mm (10.9")	1.3 kg (2.9 lbs)
GPU 100	¼"	Female/female	N/A	234 mm (9.2")	1.3 kg (2.9 lbs)
GPU 200	¼"	Female/female	50.8 mm (2.0")	307 mm (12.1")	1.7 kg (3.7 lbs)
GPU 300	¼"	Female/female	50.8 mm (2.0")	358 mm (14.1")	1.8 kg (3.8 lbs)
GPU 300 (GC 300)	¼"	Female/male	83.8 mm (3.3")	401.3 mm (15.8")	2.3 kg (5.1 lbs)
GPU 500	¼"	Female/female	76.2 mm (3.0")	351 mm (13.8")	2.7 kg (6.0 lbs)
GPU 700	¼"	Female/female	76.2 mm (3.0")	404 mm (15.9")	4.4 kg (9.6 lbs)
GPU 2500 4R	¼"	Female/female	101.6 mm (4.0")	592 mm (23.3")	6.8 kg (15 lbs)
GPU 2500 8R	½"	Female/female	101.6 mm (4.0")	714 mm (28.1")	8.0 kg (17.7 lbs)
GPU 3000	½"	Female/female	101.6 mm (4.0")	777 mm (30.6")	8.5 kg (18.7 lbs)
GPU 5000	½"	Female/female	101.6 mm (4.0")	1054 mm (41.5")	12.5 kg (27.6 lbs)
GPU 10M 8R	½"	Female/male	152.4 mm (6.0")	970 mm (38.2")	22.5 kg (49.6 lbs)
GPU 10M 12R	¾"	Female/female	152.4 mm (6.0")	1125 mm (44.3")	24.9 kg (55.0 lbs)
GPU 13M 12R	¾"	Female/female	152.4 mm (6.0")	1270 mm (50.0")	28.1 kg (62.0 lbs)
GPU 13M 16R	1"	Female/female	152.4 mm (6.0")	1308 mm (51.5")	29.5 kg (65.0 lbs)
GPU 17M 12R	¾"	Female/female	152.4 mm (6.0")	1461 mm (57.5")	32.7 kg (72.0 lbs)
GPU 17M 16R	1"	Female/female	152.4 mm (6.0")	1499 mm (59.0")	34.0 kg (75.0 lbs)
GPU 20M 12R	¾"	Female/female	152.4 mm (6.0")	1666 mm (65.6")	37.2 kg (82.0 lbs)
GPU 20M 16R	1"	Female/female	152.4 mm (6.0")	1705 mm (67.1")	38.6 kg (85.0 lbs)

DIMENSIONS

Purifier Only

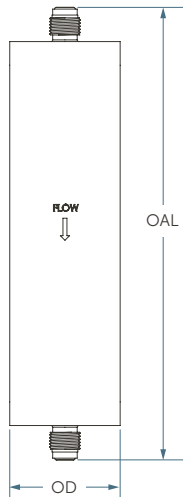

Purifier with Isolation Valves

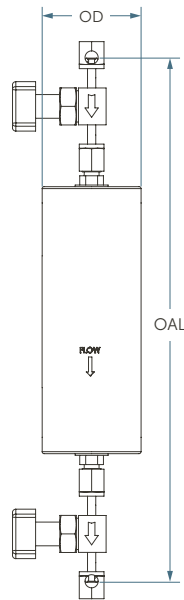

GPU 300 with GC 300 Manifold

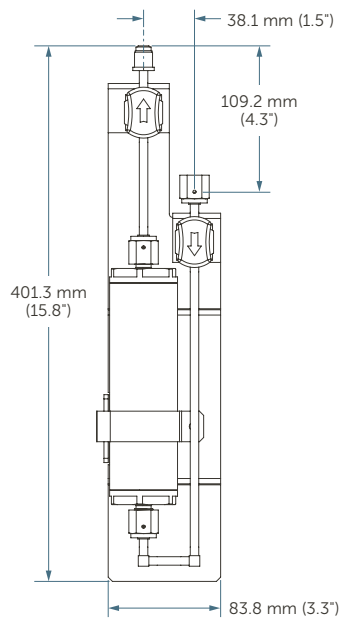

GPU 100

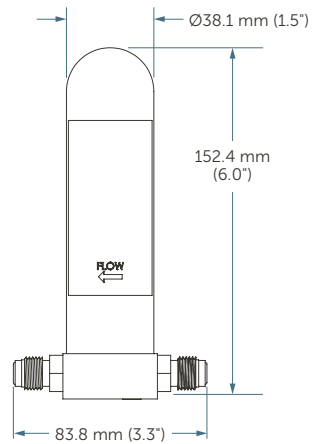

ORDERING INFORMATION

GateKeeper GPU TX Media Gas Purifiers: part number

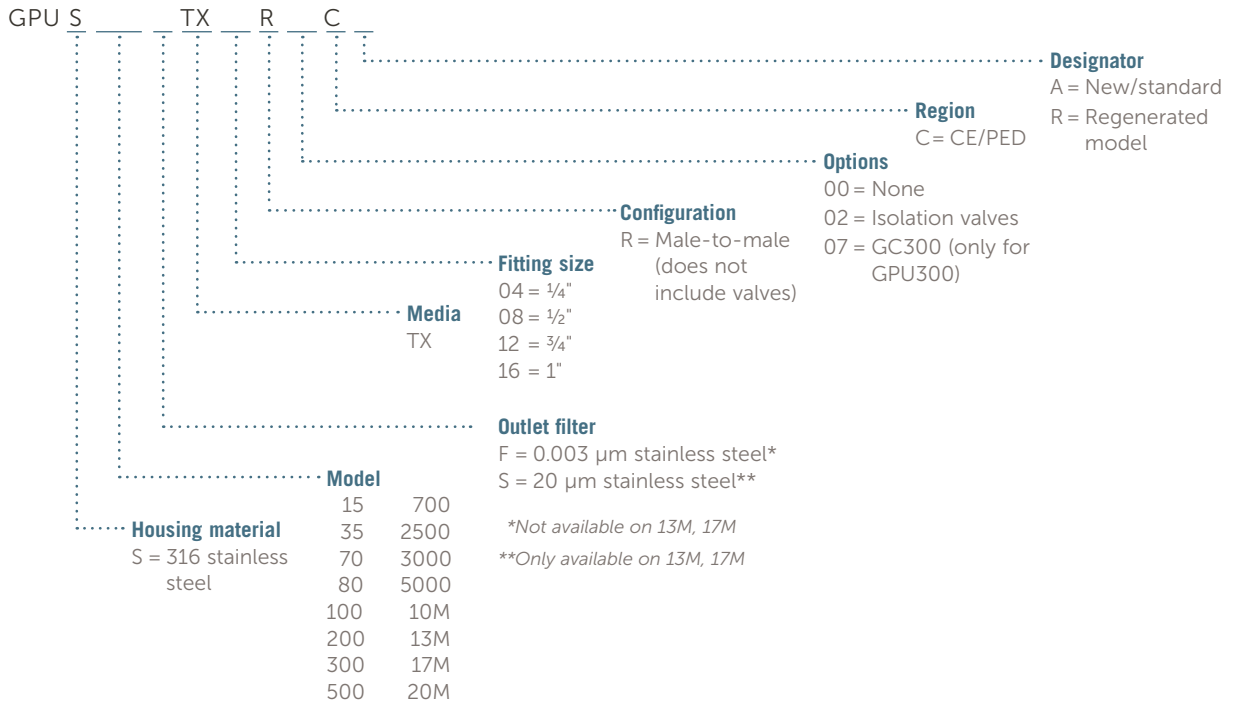

REGENERATION



REGEN, REDUCE, REUSE

[Contact](#) your local regeneration center:

ADDITIONAL OPTIONS

BYPASS ASSEMBLIES: This assembly contains additional valves and piping so the process gas can bypass around the purifier. Entegris offers 3 and 5 valve bypass assemblies for many of our standard GPU Gas Purifiers (sold separately).

FOR MORE INFORMATION

Please call your Regional Customer Service Center today to learn what Entegris can do for you. Visit entegris.com and select the [Contact Us](#) link to find the customer service center nearest you.

TERMS AND CONDITIONS OF SALE

All purchases are subject to Entegris' Terms and Conditions of Sale. To view and print this information, visit entegris.com and select the [Terms & Conditions](#) link in the footer.



Corporate Headquarters

129 Concord Road
Billerica, MA 01821
USA

Customer Service

Tel +1 952 556 4181
Fax +1 952 556 8022
Toll Free 800 394 4083

Entegris®, the Entegris Rings Design®, and other product names are trademarks of Entegris, Inc. as listed on entegris.com/trademarks. All third-party product names, logos, and company names are trademarks or registered trademarks of their respective owners. Use of them does not imply any affiliation, sponsorship, or endorsement by the trademark owner.

©2020 Entegris, Inc. | All rights reserved. | Printed in the USA | 4521-10970TAN-0920