

SmartCap™ Closure

Key-coded closure with donut breakseal for misconnect prevention

SmartCap™ closures are used together with the NOWPak® liner-based Bottle System and PDMPak® Bottle System for Pressurized Applications to seal the bottles after they are filled with chemical. The chemical-specific mechanical key-code mates with the ErgoNOW™ connector to ensure the correct chemical is connected to the correct dispense system.

APPLICATIONS

- Designed for applications where multiple chemicals are used

FEATURES & BENEFITS

- Mechanical key-code mates only to the corresponding ErgoNOW key-coded connector to prevent dispensing the wrong material
- Breakseal closure minimizes exposure of critical materials to the environment during installation of the dispense connector
- Closures are custom coded to uniquely identify customers' critical materials



SCG-XX-YY-ZZ SmartCap Closure

DIMENSIONS

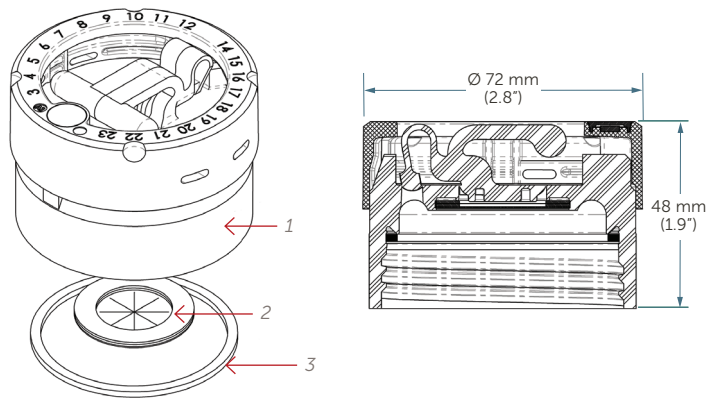

Item	Description	Quantity
1	Key-coded SmartCap closure	1
2	Donut breakseal	1
3	Gasket	1

SPECIFICATIONS

Part number	SCG-XX-YY-ZZ (XX-YY-ZZ represents the key-code)	
Materials of construction	Closure body	LLDPE
	Breakseal	Pre-cleaned, PTFE wetted surface with PE nonwetted surface
	Gasket	PE foam
	Key-coded ring	PP
	Target	Nickel-plated neodymium magnet
	Target cap	PP black
Weight	60 g (0.13 lb)	
Closure thread	Modified 63 mm buttress thread, 4.24 mm (0.167") pitch	
Application torque	9.3 ±0.3 N•m (95 ±3 kgf-cm, 80 – 85 in•lb)	
Manufacturing standards	Fabricated and tested in a Class 5 Cleanroom as per International Standard ISO 14644-1:1999 Cleanrooms and associated controlled environments – Part 1: Classification of air cleanliness.	
Cleanliness	Closure assembly to be free from lubricants and other extraneous foreign materials consistent with Entegris' processes and procedures.	
Packaging	Closure assemblies are bulk packaged in heat-sealed PE bags, then placed in a corrugated shipping carton. Each heat-sealed PE bag contains 25 SmartCap closures. Each shipping carton contains 50 SmartCap closures.	
Labeling	Each SmartCap closure assembly may optionally be labeled with a customer-specified label format. This label format may include customer-specified information such as: part number, bar code, process chemical or other customer-specified text. Each heat-sealed bag of 25 SmartCap closures is labeled with the part number, batch number and bag quantity. Each corrugated shipping carton is labeled with the part number, batch number and box quantity.	
Shipping information	Box quantity	50 (2 bags of 25)
	Box dimensions	476 mm L x 295 mm W x 197 mm H (18.7" L x 11.6" W x 7.8" H)

ORDERING INFORMATION

SmartCap closure with donut breakseal: part number

SCG - XX - YY - ZZ

Closure

SCG = SCG type SmartCap

Key-code

Contact Entegris to obtain customer specific key-code

SmartCap Closure Accessories

Part number	Description
NA-47	Tear tab removal tool
NA-33	Torque wrench, 3/8", 0 – 150 lbf•in
NA-51-A-XXYYZZ	Torque tool for SmartCap with keyed insert. Contains NA-51 torque tool body, and NA-51-XXYYZZ keyed insert. NA-51 and NA-51-XXYYZZ are also available for purchase separately.
NA-42	Torque tool adapter for SmartCap
NA-65-100	Plug for SmartCap disposal (Quantity of 100)
NA-46-250	Shipping ring for NC-W1, NC-W2, and SmartCap closures (quantity of 250)
NA-11-01-1	UN rated shipping box, for one 1-liter NOWPak bottle
NA-11-01-6	UN rated shipping box, for six 1-liter NOWPak bottles
NA-11-02-1	UN rated shipping box, for one 2.5-liter NOWPak bottle

Part number	Description
NA-11-04-1	UN rated shipping box, for one 4-liter NOWPak bottle
NA-11-04-4	UN rated shipping box, for four 4-liter NOWPak bottles
NA-11-05-1	UN rated shipping box, for one 10-liter NOWPak bottle
NA-11-05-2	UN rated shipping box, for two 10-liter NOWPak bottles
NA-74-01-6	Japanese, UN rated shipping box, for six 1-liter NOWPak bottles
NA-74-02-4	Japanese, UN rated shipping box, for four 2.5-liter NOWPak bottles
NA-74-04-1	Japanese, UN rated shipping box, for one 4 liter NOWPak bottle
NA-74-04-4	Japanese, UN rated shipping box, for four 4-liter NOWPak bottles
NA-74-05-1	Japanese, UN rated shipping box, for one 10-liter NOWPak bottle
NA-74-05-2	Japanese, UN rated shipping box, for two 10-liter NOWPak bottles

LIMITED WARRANTY

Entegris' products are subject to the Entegris, Inc. General Limited Warranty. To view and print this information, visit entegris.com and select the Legal & Trademark Notices link in the footer. Entegris does not warranty any failure in the case of customers using unapproved foreign components.

FOR MORE INFORMATION

Please call your Regional Customer Service Center today to learn what Entegris can do for you. Visit entegris.com and select the Contact Us link to find the customer service center nearest you.

TERMS AND CONDITIONS OF SALE

All purchases are subject to Entegris' Terms and Conditions of Sale. To view and print this information, visit entegris.com and select the Terms & Conditions link in the footer.



Corporate Headquarters
129 Concord Road
Billerica, MA 01821
USA

Customer Service
Tel +1 952 556 4181
Fax +1 952 556 8022
Toll Free 800 394 4083

Entegris®, the Entegris Rings Design™, Pure Advantage™, SmartCap™, NOWPak®, PDMPak® and ErgoNOW™ are trademarks of Entegris, Inc.

©2016-2017 Entegris, Inc. | All rights reserved. | Printed in the USA | 7119-8147ENT-0217