

Optimizer[®] HV Filter

Point-of-use filtration of high viscosity fluids

The Optimizer[®] HV cartridge filter is specially designed for use with photolithography and polyimide process fluids at ambient temperatures. Constructed from ultra-high molecular weight polyethylene (UPE) membrane, the Optimizer HV cartridge filter is a cost effective, reliable filter that delivers outstanding particle retention and high flow rates in the most demanding high viscosity chemical applications.

The unique membrane provides excellent retention performance and low metals and organic extractables, reducing cost of ownership through superior performance, less downtime, and ease of use.

APPLICATIONS

- Semiconductor photolithography applications
- Point-of-tool, high viscosity photochemical applications

FEATURES & BENEFITS

Unique filter design	Optimized for high flow rates of high viscosity polyimide and related photolithography solutions
UPE membrane	Eliminates prewetting and flushing Saves time, increases equipment uptime Provides better, more consistent filtration
Ultra-high purity O-ring material	Better protects your process



For use in the most demanding high viscosity chemical applications

SPECIFICATIONS

Materials	Membrane	Ultra high molecular weight polyethylene (UPE)
	Core, cage, and endcap	Polyethylene
	O-ring	Kalrez® 6375UP perfluoroelastomer size 2-015
Connections	Fits any 40-stack housing with 2-015 O-ring connection	
Membrane Area	3400 cm ² (3.66 ft ²)	
Dimensions	Diameter	66.7 mm (2.63") nominal
	Length	113 mm (4.45") nominal
Maximum operating conditions	Maximum forward differential pressure	0.34 MPa (3.4 bar, 50 psid) @ 25°C (77°F)
	Maximum reverse differential pressure	0.27 MPa (2.7 bar, 39 psid) @ 25°C (77°F)
	Maximum operating temperature	60°C (140°F)

Entegris recommends that customers change filters at least annually to ensure optimal filtration performance. Routine annual changeout will also reduce the potential of chemical leakage that can result from excessive usage. Our standard warranty period is 1 year (from Entegris ship date).

PERFORMANCE DATA

Optimizer HV40 Cartridge Filters
Maximum Filtration Rate vs. Viscosity

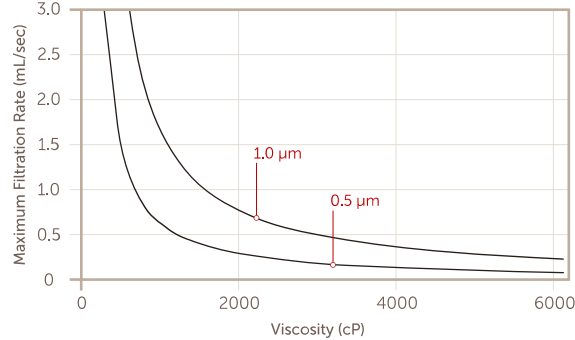

Optimizer HV40 Cartridge Filters
Flow Performance — 4317 cP Mineral Oil

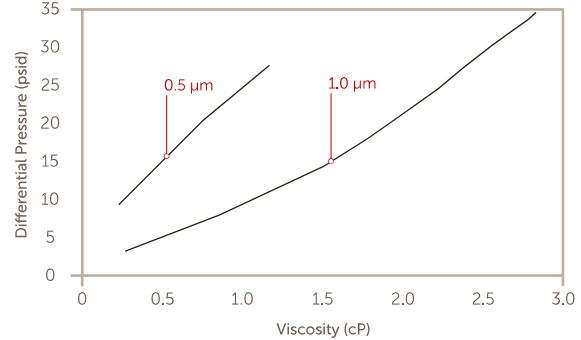

DIMENSIONS

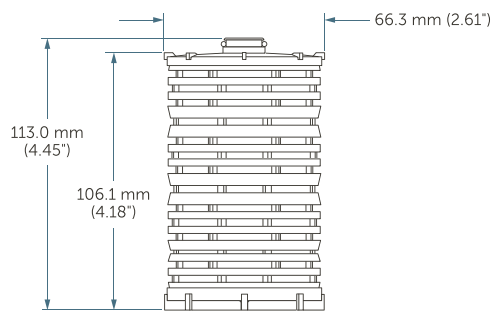

ORDERING INFORMATION

PART NUMBER	RETENTION RATING
CWAA40KM1	1 µm
CWAH40KM1	0.5 µm

FOR MORE INFORMATION

Please call your Regional Customer Service Center today to learn what Entegris can do for you. Visit entegris.com and select the [Contact Us](#) link to find the customer service center nearest you.

TERMS AND CONDITIONS OF SALE

All purchases are subject to Entegris' Terms and Conditions of Sale. To view and print this information, visit entegris.com and select the [Terms & Conditions](#) link in the footer.



Corporate Headquarters
129 Concord
Billerica, MA 01821
USA

Customer Service
Tel +1 952 556 4181
Fax +1 952 556 8022
Toll Free 800 394 4083

Entegris®, the Entegris Rings Design®, and other product names are trademarks of Entegris, Inc. as listed on entegris.com/trademarks. All third-party product names, logos, and company names are trademarks or registered trademarks of their respective owners. Use of them does not imply any affiliation, sponsorship, or endorsement by the trademark owner.

©2001-2021 Entegris, Inc. | All rights reserved. | Printed in the USA | 4414-5355ENT-1221