

PrimeLock[®] Tee Adapter, MNPT Branch

A premium PFA fitting for high-purity and corrosive chemical applications

Entegris has supplied innovative connection technology into the high-purity chemical handling markets for over 30 years. Our PrimeLock[®] fittings (available in sizes from 1/4" to 1 1/2" and 40 mm) are clean, robust, and very easy to assemble. With audible and visual indicators, users can quickly verify the proper makeup of the connection. Heat is not required to assemble this fitting, saving time and money.

PrimeLock fittings perform effectively in the most demanding chemical applications at both ambient and elevated temperatures. The ultraclean design provides enhanced reliability within your system, with an all-PFA wetted construction. PrimeLock fittings are fully tested using our stringent testing and qualification methodology. This extremely robust, clean fitting is the most reliable connection technology on the market.

APPLICATIONS

- High-purity, corrosive chemical handling
- Semiconductor applications
 - Photolithography
 - Bulk chemical delivery
 - CMP
 - Wet etch and clean
 - High-temperature cleaning processes
- Solar, LED, flat panel display
- Excellent performance with low surface tension chemistries

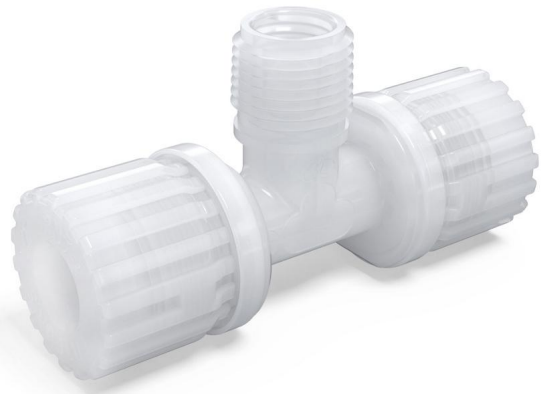

PrimeLock tee adapter, MNPT

FEATURES & BENEFITS

Ease of assembly	Provides consistent and repeatable fitting makeup
All wetted PFA components	Offers broad chemical compatibility
Robust thread design	No cross-threading, quick makeup, increased sealing force
Unique seal design	Nonwetted insert reduces entrapment, leak points, and flow interruptions
No heat required to flare tubing	Saves time and money; reduces operator variability
Connection verification ring	Audible and visual indication of proper fitting makeup
Capable of elevated temperature ratings, all sizes	Simplifies product selection and is compatible with high-temperature chemical processes
Innovative dual-wrench design for 1 1/2" or 40 mm nuts	Make it easier to assemble fittings, saving time and money

SPECIFICATIONS

		1/4" - 1 1/4" Sizes	1 1/2" and 40 mm Sizes
Materials	Body, insert, nut	PFA	PFA
	Connection verification ring	ETFE	ETFE
Operating conditions*	Media pressure	827 kPa (120 psig) @ 21°C (70°F)	689 kPa (100 psig) @ 21°C (70°F)
		276 kPa (40 psig) @ 200°C (392°F)	276 kPa (40 psig) @ 150°C (302°F)
	Temperature range (fluid)	-18° to 200°C (0°– 392°F)	-18° to 150°C (0°– 302°F)
Compliant		RoHS	RoHS

*1 1/4" PrimeLock "SpaceSaver" connections are rated to 586 kPa (85 psig) @ 100°C (212°F).

Applicable PFA Tube Dimensions

OD	OD Tolerance	Wall Thickness	Wall Thickness Tolerance
1/4" (6.35 mm)	±0.004" (±0.10 mm)	0.047" (±1.19 mm)	±0.004" (±0.10 mm)
3/8" (9.52 mm)	±0.004" (±0.10 mm)	0.062" (±1.57 mm)	±0.005" (±0.13 mm)
1/2" (12.70 mm)	±0.005" (±0.13 mm)	0.062" (±1.57 mm)	±0.005" (±0.13 mm)
3/4" (19.05 mm)	±0.005" (±0.13 mm)	0.062" (±1.57 mm)	±0.005" (±0.13 mm)
1" (25.40 mm)	±0.005" (±0.13 mm)	0.062" (±1.57 mm)	±0.005" (±0.13 mm)
1 1/4" (31.75 mm)	±0.007" (±0.18 mm)	0.075" (±1.90 mm)	±0.007" (±0.18 mm)
1 1/2" (38.10 mm) and 40 mm	±0.007" (±0.18 mm)	0.086" (±2.18 mm)	±0.007" (±0.18 mm)

Pipe Thread (NPT) Assembly Procedure

- Apply PTFE tape or paste sealant to MNPT threads starting one thread back from end of fitting.
 - When using tape, tightly wrap in direction of threads to conform tape to thread shape.
 - Use 3 1/2 to 4 wraps of tape when assembling PFA threads to PFA material.
 - Use 4 to 5 wraps of tape when assembling PFA threads to a material other than PFA.
- Thread the fitting onto the mating component until hand tight.
- Using a wrench, tighten fitting about 4 turns past hand tight.

PTFE tape = 1/2" wide for all NPT fittings

Note: PTFE tape is not recommended for use in a gaseous application.

Torque (in•lbs x .11298 = newton•m)

	In•lbs	Newton•m
1/16"	5.0	0.57
1/8"	7.0	0.79
1/4"	16	1.81
3/8"	23	2.60
1/2"	30	3.39
3/4"	54	6.10
1"	78	8.81

PERFORMANCE DATA

PrimeLock Fittings Sizes 1/4" – 1 1/4"
Pressure vs. Temperature Rating

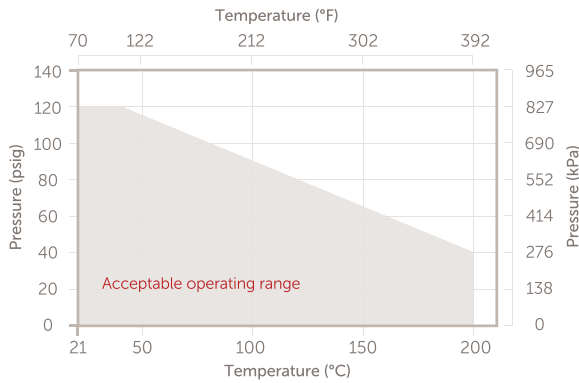

PrimeLock Fitting Sizes 1 1/2" and 40 mm
Pressure vs. Temperature Rating

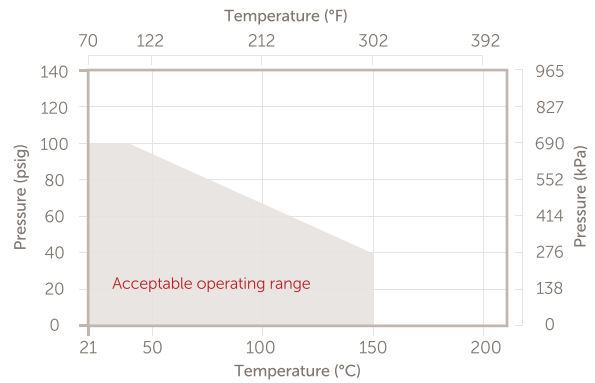

Note: 1 1/4" PrimeLock "SpaceSaver" connections are rated to 586 kPa (85 psig) @ 100°C (212°F).

Fittings Reliability Test Results

Test Type	Test Conditions	Acceptance Criteria	Results
Burst pressure	Media pressure increased until leak occurs	No external leakage prior to tube rupturing	PASS No external leakage
Cyclic pressure leak test	1/4"-1 1/4": 1241 kPa (180 psig) water @ 23°C (73°F)	No external leakage after 1 million cycles @ 1.5 x rated pressure	PASS No external leakage
	1 1/2" and 40 mm: 1034 kPa (150 psig) water @ 23°C (73°F)		
	1/4"-1 1/4": 414 kPa (60 psig) hydraulic oil @ 200°C (392°F)	No external leakage after 1 million cycles @ 1.5 x rated pressure	PASS No external leakage
	1 1/2" and 40 mm: 414 kPa (60 PSIG) hydraulic oil @ 150°C (302°F)		
High pressure leak test	Submerge fitting Apply nitrogen pressure equaling 80% of the tube burst pressure	No external leakage allowed	PASS No external leakage
Tube pull out test	Apply tensile load to tube/fitting until tube separates from fitting	1/4" (178 N) 40 lbf 3/8" (400 N) 90 lbf 1/2" (534 N) 120 lbf 3/4" (890 N) 200 lbf 1" (1112 N) 250 lbf 1 1/4" (1557 N) 350 lbf 1 1/2" and 40 mm (1779 N) 400 lbf	PASS
Chemical testing	Sulfuric acid Fluorosurfactant Copper sulfate 25% TMAH	No external leakage after 2 million cycles	PASS PASS PASS PASS

PERFORMANCE DATA

NPT Threadable Pipe Fittings

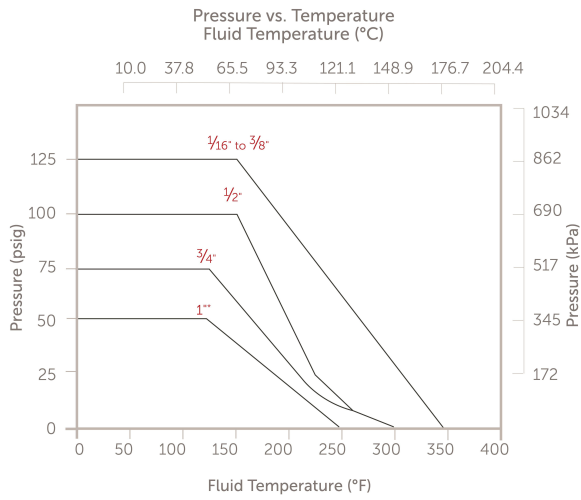

DIMENSIONS

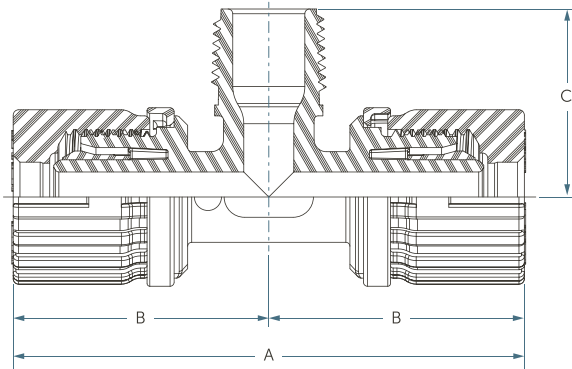

Part Number	Leg 1	Leg 2	Leg 3	Orifice	Dimensions		
					A	B	C
PT-8K8NM8K-3	1/2" PrimeLock	1/2" MNPT	1/2" PrimeLock	0.37" (9.4 mm)	3.78" (96.0 mm)	1.89" (48.0 mm)	1.39" (35.3 mm)

ORDERING INFORMATION

PART NUMBER	LEG 1	LEG 2	LEG 3
PT-8K8NM8K-3	1/2" PrimeLock®	1/2" MNPT	1/2" PrimeLock®

FOR MORE INFORMATION

Please call your Regional Customer Service Center today to learn what Entegris can do for you. Visit entegris.com and select the [Contact Us](#) link to find the customer service center nearest you.

TERMS AND CONDITIONS OF SALE

All purchases are subject to Entegris' Terms and Conditions of Sale. To view and print this information, visit entegris.com and select the [Terms & Conditions](#) link in the footer.



Corporate Headquarters
129 Concord
Billerica, MA 01821
USA

Customer Service
Tel +1 952 556 4181
Fax +1 952 556 8022
Toll Free 800 394 4083

Entegris®, the Entegris Rings Design®, and other product names are trademarks of Entegris, Inc. as listed on entegris.com/trademarks. All third-party product names, logos, and company names are trademarks or registered trademarks of their respective owners. Use of them does not imply any affiliation, sponsorship, or endorsement by the trademark owner.

©2017-2022 Entegris, Inc. | All rights reserved. | Printed in the USA | 3110-12444DSA-0723

www.entegris.com