

Sentry[®] QCII Dispense Head Key-Code Ring

Change procedure

Change Procedure for:

These change procedures apply to all standard Sentry[®] QCII dispense heads.

DISASSEMBLY PROCEDURE FOR REPLACING OLD KEY-CODE RING

1. Put protective cap (P1) onto the dispense head subassembly sealing surface (see Figure 1).
2. Using the side cutter (S1), first cut a "V" notch into the retaining ring (see Figure 2). Do not scratch or gouge the dispense head shoulder or sealing surface.

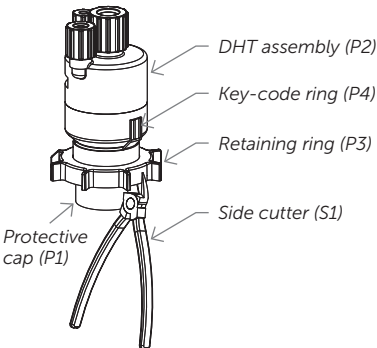

Figure 1.

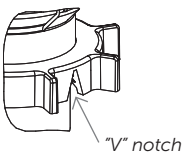

Figure 2.

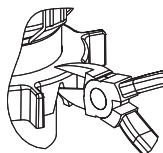

Figure 3.

3. Using the "V" notch as the starting point, next cut straight across the top of the retaining ring (see Figure 3) and remove.
4. Starting at one of the four molded slots, cut away the key-code ring from the dispense head. Cutting upward works best (see Figure 4). Cut through the entire length of the key code ring and remove (see Figure 5).

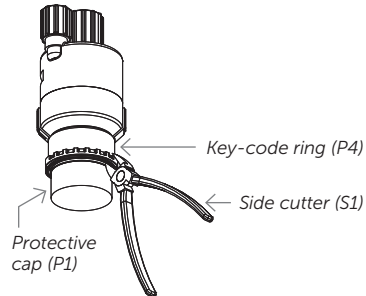

Figure 4.

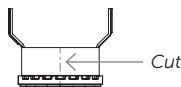

Figure 5.

REASSEMBLY PROCEDURE

1. Insert key-code ring (P4) into the retaining ring with threads toward the key-code ring (see Figure 6).

NOTE: Make sure the retaining ring is oriented as shown in Figure 6 or it will not function.

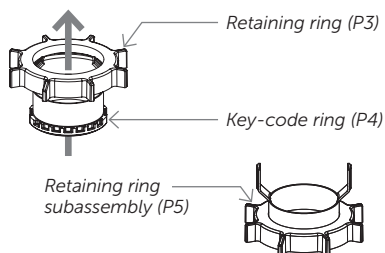

Figure 6.

2. Push retaining ring subassembly (P5) over the dispense head subassembly (P6) until it snaps into place (see Figure 7).

NOTE: Do this by hand. Considerable force is required and gloves are recommended.

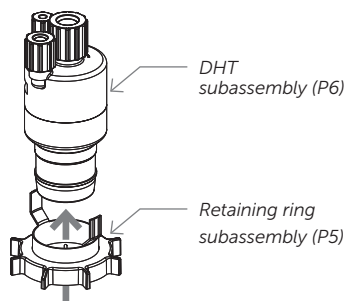

Figure 7.

3. After new retaining ring is assembled, pull the retaining ring downward to ensure it is completely engaged to the dispense head (see Figure 8).

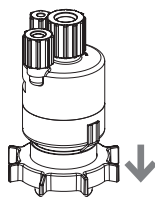

Figure 8.

FOR MORE INFORMATION

Please call your Regional Customer Service Center today to learn what Entegris can do for you. Visit entegris.com and select the Contact Us link to find the customer service center nearest you.

TERMS AND CONDITIONS OF SALE

All purchases are subject to Entegris' Terms and Conditions of Sale. To view and print this information, visit entegris.com and select the Terms & Conditions link in the footer.



Corporate Headquarters
129 Concord Road
Billerica, MA 01821
USA

Customer Service
Tel +1 952 556 4181
Fax +1 952 556 8022
Toll Free 800 394 4083

Entegris®, the Entegris Rings Design™, Pure Advantage™ and Sentry® are trademarks of Entegris, Inc.
©2004-2017 Entegris, Inc. | All rights reserved. | Printed in the USA | 3560-2008ENT-0617