

FluoroPure® HDPE Drum – Packing Group I

The only HDPE drum on the market approved to transport UN Packing Group I chemicals

Entegris is first to market an HDPE 1H1 drum that meets the requirements for transporting UN Packing Group I chemicals. This drum is the first product produced to adhere to these stringent requirements.

APPLICATIONS

- The drum is ideal for transportation of chemicals like HCl and NH₄OH that require a higher kPa rating because of vapor pressure buildup.
- This drum meets the transportation requirements of most Group I chemicals with a specific gravity of ≤1.9.

FEATURES & BENEFITS

- The drum is fully UN approved with both Sentry® QCIII and QCII patented Quick Connect systems.
- This product is also approved for low pressure dispense (140 kPa).
- Because of the drum's unique semi-elliptical top and bottom design combined with a low sump feature, the residual is minimized.
- The drum has high chimes for protection of the closure connections and to keep the drum from rocking when pressurized.

SPECIFICATIONS

- This drum is molded using Entegris' multilayer blowmolding technology allowing for an ultraclean inner layer for your ultra-pure chemistry.
- The drum can be made with the Trilayer or Advantage Trilayer inner layer resins.
- The drum is assembled in a Class 6 cleanroom with pre-cleaned closure components.



DIMENSIONS

- 584 mm (23.0") D x 953 mm (37.53") H

PERFORMANCE DATA

Residual After Pump Dispense, 250–500 mL

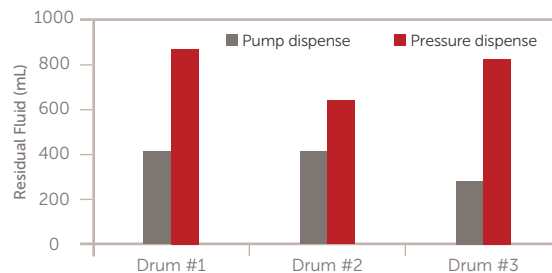

ORDERING INFORMATION

FluoroPure® HDPE Drum—Packing Group I: part number

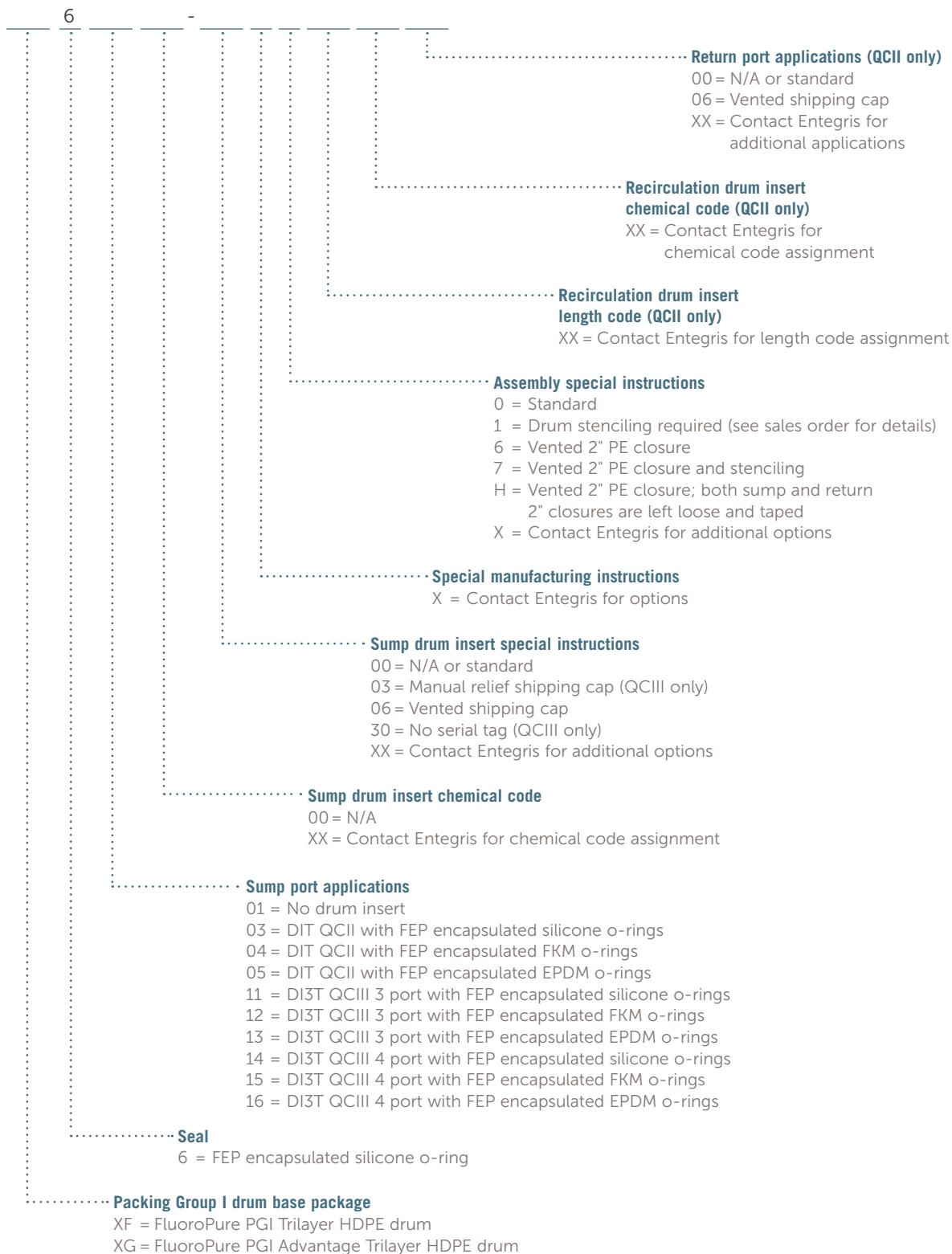

SPECIFICATIONS

Materials of construction	Body	Blowmolded multilayer high-density PE
	Chimes	Injection-molded high-density PE
Tare weight	16.2 kg (35.7 lbs)	
Size/volume	182 L (48 gal)	
Approvals	UN 1H1/X1.9/320/TW	
	Entegris CR 6004 2.2	

DIMENSIONS

Cross-section View

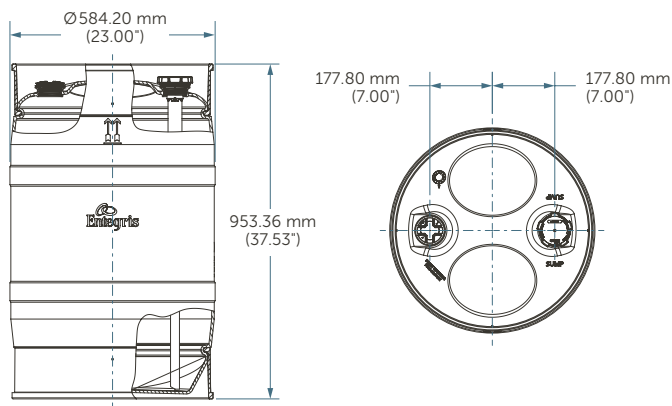

FOR MORE INFORMATION

Please call your Regional Customer Service Center today to learn what Entegris can do for you. Visit entegris.com and select the Contact Us link to find the customer service center nearest you.

TERMS AND CONDITIONS OF SALE

All purchases are subject to Entegris' Terms and Conditions of Sale. To view and print this information, visit entegris.com and select the Terms & Conditions link in the footer.



Corporate Headquarters
129 Concord Road
Billerica, MA 01821
USA

Customer Service
Tel +1 952 556 4181
Fax +1 952 556 8022
Toll Free 800 394 4083

Entegris®, the Entegris Rings Design™, Pure Advantage™, Sentry®, and FluoroPure® are trademarks of Entegris, Inc.

©2017 Entegris, Inc. | All rights reserved. | Printed in the USA | 3560-8346ENT-1017