

InVue® GV148 Liquid Concentration Monitor

*Real-time process monitoring in
an integrated, compact package*

The InVue® GV148 liquid concentration monitor delivers real-time process fluid concentration measurements for chemical blending, spiking, and dilution without process intrusion or interruption.

Integrated in a compact, ultra-high purity package, the GV148 liquid concentration monitor delivers cost-effective, high-performance concentration monitoring, enabling greater process efficiency for front-end-of-line (FEOL), back-end-of-line (BEOL), and sub-fab delivery chemical systems. This increased process visibility results in tighter process control, higher wafer throughput, reduced chemical usage, and decreased scrap.

POWERFUL USER INTERFACE SOFTWARE

A dynamic and user-friendly Windows®-based HMI software application supports the GV148 configuration and monitoring in real time. This software allows users to:

- Obtain real-time refractive index, fluid temperature, and concentration information
- Customize refractive index to concentration conversions
- Acquire and analyze data for chemistry specific temperature compensation
- Manipulate sensor averaging method
- View current alarms, system events, and alarm history
- Re-zero refractive index
- Configure analog outputs



PROVEN REFRACTIVE INDEX TECHNOLOGY

The GV148 monitor uses proven refractive index technology packaged in a compact configuration to provide an accurate, safe, and repeatable means of measuring liquid concentration. The in-line sensor accurately measures the process fluid index of refraction (IoR) and temperature. This information is then used to calculate process fluid concentration.

Principle of Operation

Using refractive index technology, the InVue GV148 concentration monitor operates when light reflects off the window/liquid interface into the photo diode array (PDA). The angle of reflection is determined by the refractive index ratio between the liquid and window. The custom designed Entegris algorithm measures small changes in the reflected light intensity. This reflection geometry and miniaturization enable concentration monitoring performance unmatched by other technologies.

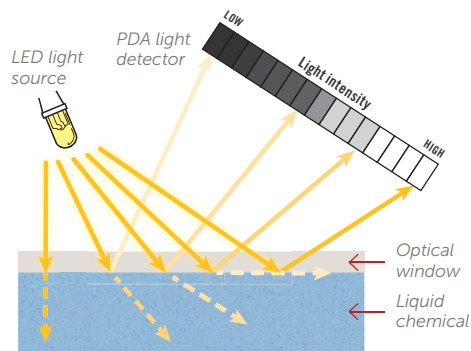

APPLICATIONS

- H₂O₂ spiking in slurry
- Slurry dilution
- Proprietary additive blending
- Global and local loop monitoring
- Batch tool chemical blending
- Bath lifetime detection
- Post-CMP clean chemical blending

FEATURES & BENEFITS

Measurement based on index of refraction	Provides real-time concentration and temperature validation for process control Fast response time for immediate excursion detection Measures concentration in various media, including non-conductive fluids Non-intrusive, maintaining chemical purity and cleanliness In-line for process efficiency
Ultrapure wetted surfaces of fluoropolymers and sapphire	Maintains chemical purity and cleanliness
Small footprint with integral electronics	Minimizes overall tool size Easily integrates into new and existing tools spaces
HMI software	Tool for real-time data logging and analysis Allows for easy custom configuring of the monitor for customer proprietary chemistries Includes detailed event log for close monitoring of system events, parameter changes, and alarm history
Multiple communication option	RS485, RS422, 4-20mA Flexible to meet various control architectures
Fully potted sensor	Provides accuracy, repeatability, and reliability in the harshest environments
Ambient light cancellation algorithm	Improves accuracy in the presence of ambient light
Sensor has no consumable parts	Requires minimal hardware and preventive maintenance
Window cleaning port	Allows easy access to the sapphire window for manual cleaning
LED status lights	Provide visual indication of monitor heartbeat, communications, and error

SPECIFICATIONS

Pressure and thermal	Maximum pressure	80 psig at 40°C (104°F)
	Process fluid temperature range	20° to 40°C (68° to 104°F)
	Ambient temperature range	20° to 35°C (68° to 95°F)
	Storage temperature range	-15° to 40°C (5° to 104°F)
RI measurement	RI measurement range**	1.32 – 1.40 nD
	Accuracy	$\pm 2 \times 10^{-4}$ nD (@ 20°C [68°F] from 1.332987 to 1.4000 nD)
	Repeatability	5×10^{-5} nD (in clear fluid @20°C [68°F])
	Precision	3×10^{-6} nD (in DI water @20°C [68°F])
	Response time	<3 sec unaveraged response to 63% of steady state change
	Drift	< 5×10^{-5} nD/30 days (@ 20°C [68°F])
	Pressure sensitivity (typical)	8×10^{-7} nD/psig (in DI water @ 20°C [68°F])
Sensor materials of construction	Flow cell body	Polytetrafluoroethylene (PTFE)*
	Optical window	Single-crystal sapphire*
	Cable jacket	Polyvinylchloride (PVC)
	Bonnet, enclosure	Polyvinylidene fluoride (PVDF)
	Mounting plate	Polypropylene (PP)
Electrical	Cable connection	19 pin Turck® male
	Current rating	1.0 A at start-up; 0.5 A during operation
	Main voltage input	24 VDC
	IO voltage input	12 – 24 VDC
	Short protection	Yes
	External LEDs	4
	Analog outputs	4 – 20 mA concentration, fluid temperature, refractive index (RI)
	Discrete digital inputs	2
	Discrete digital outputs	2, 80 mAdc maximum (each)
	Re-zero	Digital input, serial command, or HMI software
Serial communication	RS485	2-wire or 4-wire
	RS422	4-wire
	Operating system compatibility	Windows 7 or 10
	Network compatible	Yes
Orientation	Any	
Enclosure	IP54	
Approvals	 IECEX ETL 19.0009X Ex ic IIC T5 Gc	
ROHS compliant	Yes	

*Wetted components.

**For fluids with a refractive index outside this range, please contact Entegris.

DIMENSIONS

Front View

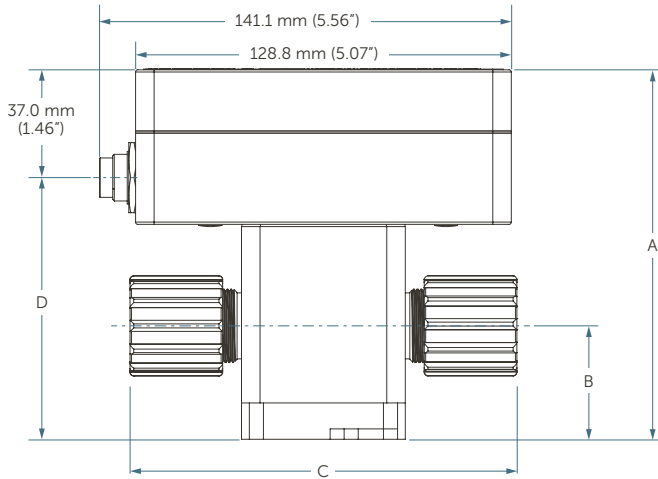

Side View

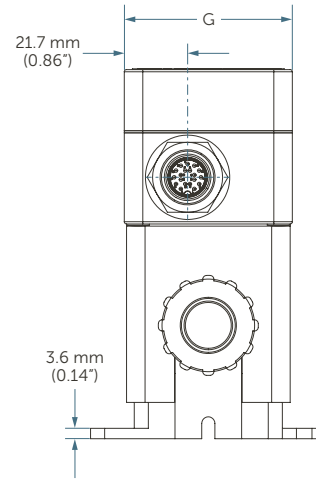

Top View

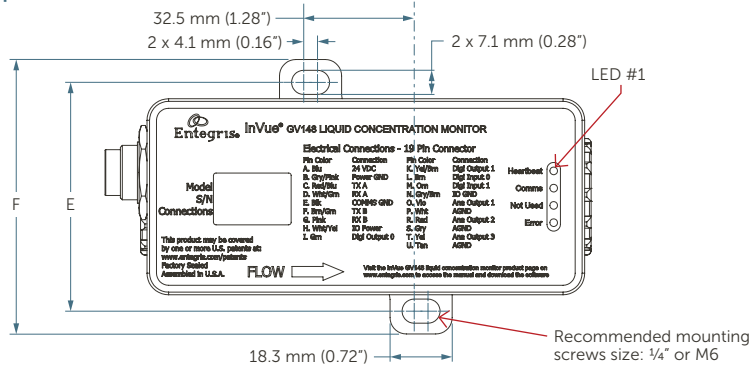

		TOTAL HEIGHT	FLOWPATH HEIGHT	FLOWPATH LENGTH	CONNECTOR HEIGHT	MTG HOLE WIDTH	MTG FLANGE WIDTH	COVER/SKIRT WIDTH
Connection Size	Size	A	B	C	D	E	F	G
Flaretek®	1/4"	114.6 mm (4.51")	33.1 mm (1.30")	108.0 mm (4.25")	77.6 mm (3.06")	67.3 mm (2.65")	80.8 mm (3.18")	57.7 mm (2.27")
	3/8"	117.7 mm (4.64")	34.7 mm (1.37")	113.5 mm (4.47")	80.8 mm (3.18")	67.3 mm (2.65")	80.8 mm (3.18")	57.7 mm (2.27")
	1/2"	120.9 mm (4.76")	36.3 mm (1.43")	117.6 mm (4.63")	84.0 mm (3.31")	67.3 mm (2.65")	80.8 mm (3.18")	57.7 mm (2.27")
	3/4"	126.6 mm (4.99")	38.9 mm (1.53")	132.1 mm (5.20")	89.7 mm (3.53")	67.3 mm (2.65")	80.8 mm (3.18")	57.7 mm (2.27")
	1"	133.7 mm (5.27")	42.0 mm (1.66")	138.9 mm (5.47")	96.8 mm (3.81")	67.3 mm (2.65")	80.8 mm (3.18")	57.7 mm (2.27")
PrimeLock®	1/2"	120.9 mm (4.76")	36.3 mm (1.43")	116.6 mm (4.59")	84.0 mm (3.31")	67.3 mm (2.65")	80.8 mm (3.18")	57.7 mm (2.27")
	1"	137.4 mm (5.41")	45.7 mm (1.80")	142.0 mm (5.59")	100.4 mm (3.95")	72.4 mm (2.85")	85.9 mm (3.38")	61.2 mm (2.41")
Pillar	1/4"	114.6 mm (4.51")	33.1 mm (1.30")	100.5 mm (3.96")	77.6 mm (3.06")	67.3 mm (2.65")	80.8 mm (3.18")	57.7 mm (2.27")
	3/8"	117.7 mm (4.64")	34.7 mm (1.37")	112.5 mm (4.43")	80.8 mm (3.18")	67.3 mm (2.65")	80.8 mm (3.18")	57.7 mm (2.27")
	3/4"	126.6 mm (4.99")	38.9 mm (1.53")	134.4 mm (5.29")	89.7 mm (3.53")	67.3 mm (2.65")	80.8 mm (3.18")	57.7 mm (2.27")

ORDERING INFORMATION

InVue GV148 Liquid Concentration Monitor: part number

GV1 M A H0

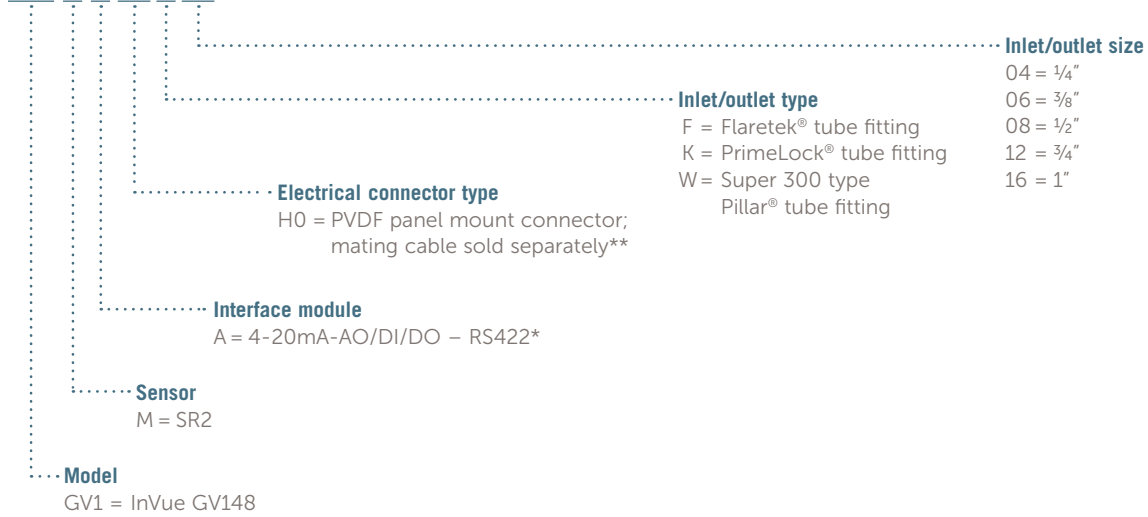

*4-20mA Analog Output – Quantity 3; Digital Input – Quantity 2; Digital Output – Quantity 2

Accessory**

Part number	Description
GV1CBLH04	19-pin Turck connector with 4.0 meter (13.12') PVC-jacketed cable
GV1USBCVT	USB to 4-wire serial converter

FOR MORE INFORMATION

Please call your Regional Customer Service Center today to learn what Entegris can do for you. Visit entegris.com and select the [Contact Us](#) link to find the customer service center nearest you.

TERMS AND CONDITIONS OF SALE

All purchases are subject to Entegris' Terms and Conditions of Sale. To view and print this information, visit entegris.com and select the [Terms & Conditions](#) link in the footer.



Corporate Headquarters
129 Concord Road
Billerica, MA 01821
USA

Customer Service
Tel +1 952 556 4181
Fax +1 952 556 8022
Toll Free 800 394 4083

Entegris®, the Entegris Rings Design®, and other product names are trademarks of Entegris, Inc. as listed on entegris.com/trademarks. All third-party product names, logos, and company names are trademarks or registered trademarks of their respective owners. Use of them does not imply any affiliation, sponsorship, or endorsement by the trademark owner.

©2020-2026 Entegris, Inc. | All rights reserved. | Printed in the USA | 3965-10898ENT-0526